



IN2CONNECT
ELECTRONIC CONNECTORS

connectors micronector 200

High density

2mm pitch connectors

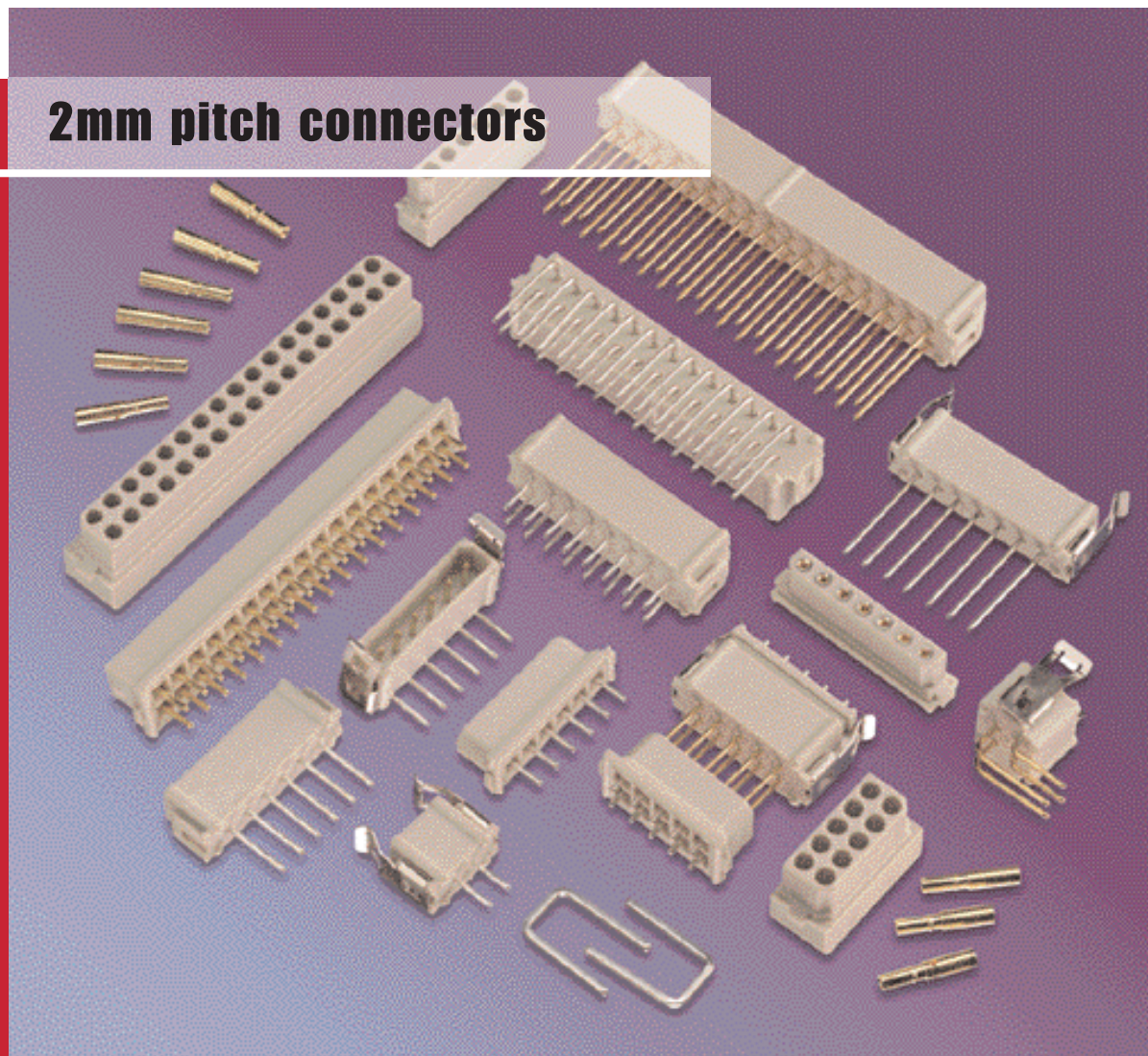

TW **McMurdo**
Connectors

High density

A range of high specification 2mm pitch connectors meeting demanding performance requirements and available released to BS 9525 – F0033

2mm pitch connectors

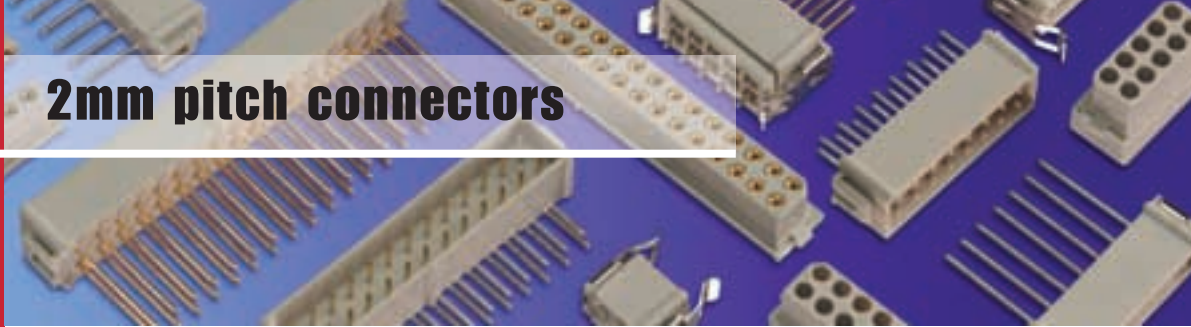

FEATURES

- 2mm pitch
- High reliability circular contacts for increased vibration and shock resistance
- Connector polarisation
- Small footprint for increased packing density
- Low profile

- 7 Sizes single row (2 to 17 way)
- 11 Sizes two row (4 to 34 way)
- Positive latching available
- Male straight and 90° p.c. terminations
- Female straight p.c. and crimp terminations

- Retaining strap available for extra strain relief
- Manufactured as a commercial connector or released to BS 9525 – F0033
- Special versions available including surface mount.
- Please contact sales department for further details.

Technical Data

MATERIALS

Insulator	Glass filled thermoplastic rated UL94V-0
Contact	Copper alloy plated hard acid gold
Termination	Hard acid gold or tin/lead

MECHANICAL

Operations	500
Insertion and withdrawal force (per contact pair)	2.0N max., 0.2N min.
Contact retention	10N min.
Crimp barrel accommodation	22 AWG – 28AWG to BS G 210 type A

ELECTRICAL

Current – individual contact (in isolation)	at 25°C Tamb 2.0A max at 85°C Tamb 1.75A max
- all contacts (simultaneously)	at 25°C Tamb 1.75A max at 85°C Tamb 1.5A max
Working voltage (DC or AC peak)	120V
Proof voltage (DC or AC peak)	360V
Contact resistance - (initially)	20mΩ max
- (after conditioning)	25mΩ max
Insulation resistance – (initially)	1000mΩ min
- (after conditioning)	100mΩ min

ENVIRONMENTAL

Temperature Range	-55°C to +125°C
Vibration severity (General)	10 Hz, 2000Hz 0.75mm/98m/s ² (10g _n) duration 6h
Bump severity	390m/s ² (40g _n) 4000 ±10 bumps
Shock	981m/s ² (100g _n), for 6ms
Acceleration severity	490m/s ² (50g _n)

Crimp details

Preferred wire type BS G 210 (Type A) *Also suitable for use with 24 A.W.G. DEF-STAN 61-12 (Part 6 Type 1) PVC

Termination Type	Crimp barrel accommodation	Wire Size/Crimp Tool Setting			
		22 A.W.G.	24 A.W.G.	26 A.W.G.	28 A.W.G.
C*	24-28 A.W.G.	-	7	6	6
D	22 A.W.G.	6	-	-	-

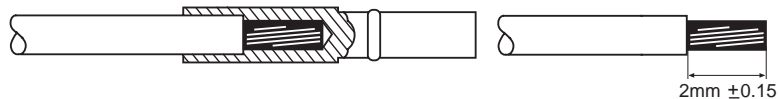

NOTE: Whilst a crimp contact withdrawal tool (MP6808) is available as an optional accessory, it is only suitable for removal of ALL contacts when the moulding MUST be replaced prior to reinsertion of the contacts.

Minimum spacing

End to end dimensions

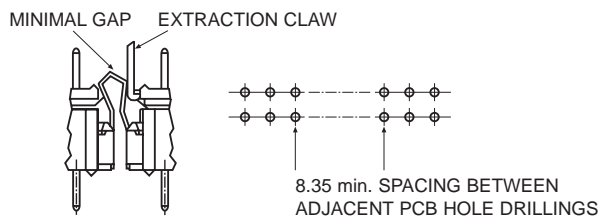

Board

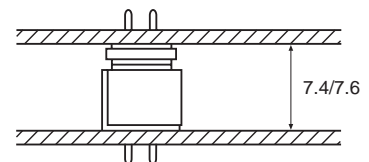

Male Straight p.c.

termination type T, X and Y

BS Style B5743

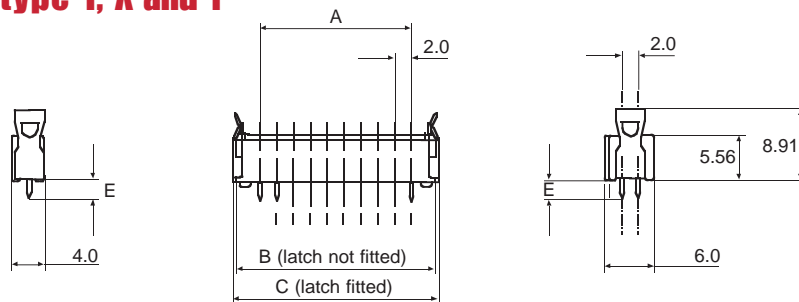

Male 90° p.c.

termination type L

BS Style B5743

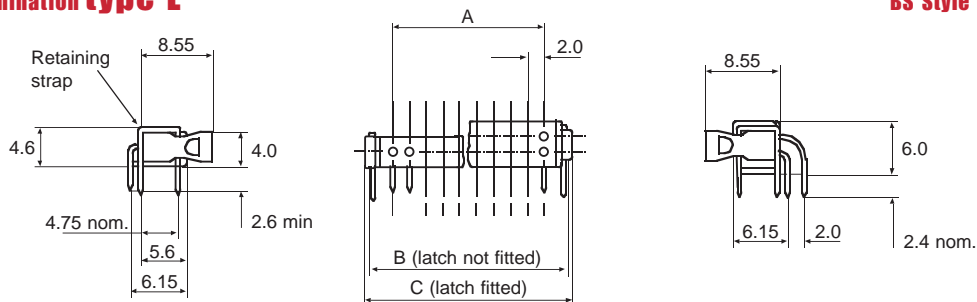

Female Straight p.c.

termination type T and N

BS Style B5741

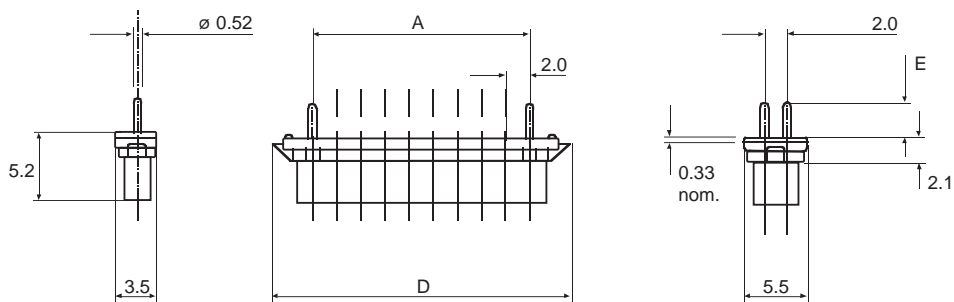

Female Crimp

termination type C and D

BS Style B5740

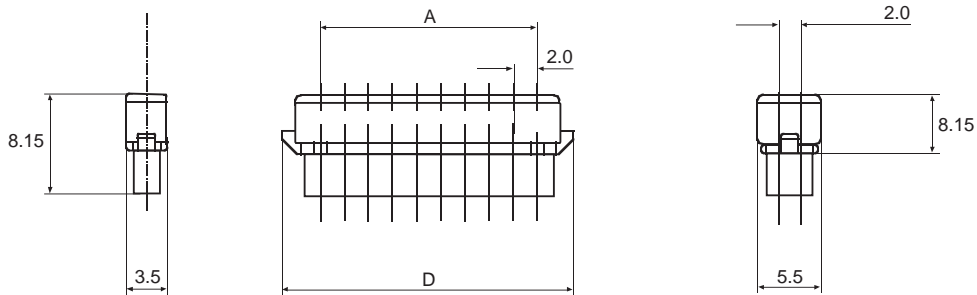

PCB Layouts

for Male connectors type L for Male and Female Types T, X, Y and N omit 1.1/1.0mm holes

Plug viewed from above,
socket viewed from
below.

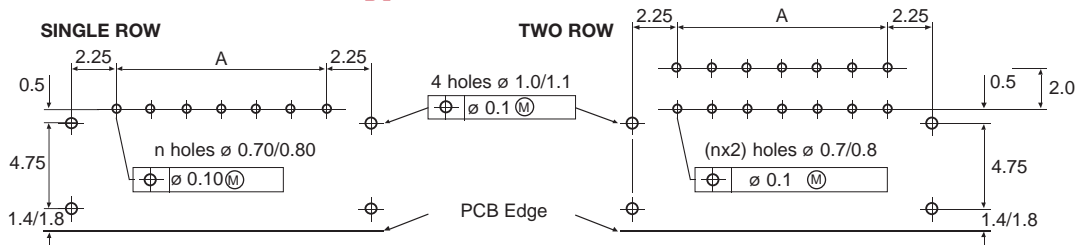

Contact Arrangement Single Row	2	3	4	5	6	7				17	
Contact Arrangement Two Row	4	6	8	10	12	14	16	18	20	26	34
A	2.0	4.0	6.0	8.0	10.0	12.0	14.0	16.0	18.0	24.0	32.0
B	7.6	9.6	11.6	13.6	15.6	17.6	19.6	21.6	23.6	29.6	37.6
C	8.1	10.1	12.1	14.1	16.1	18.1	20.1	22.1	24.1	30.1	38.1
D	7.3	9.3	11.3	13.3	15.3	17.3	19.3	21.3	23.3	29.3	37.3
Termination Type	T		Y			X			N		
E (nom.)	2.9		5.35			9.35			1.1		

ORDERING information

McMurdo reference for CONNECTORS

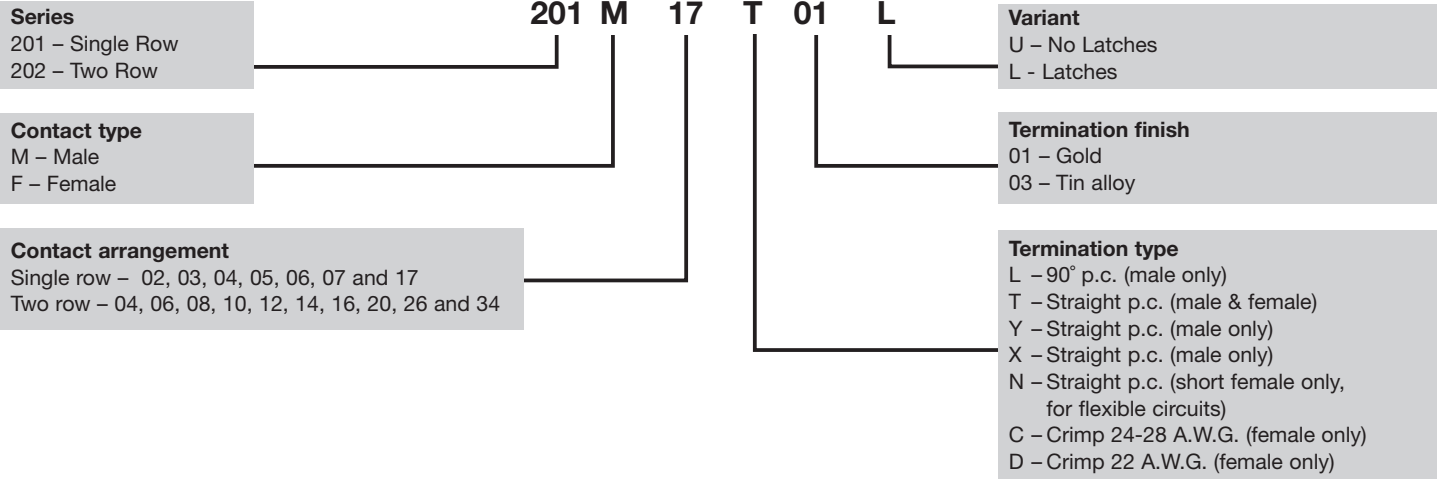

BS reference for CONNECTORS

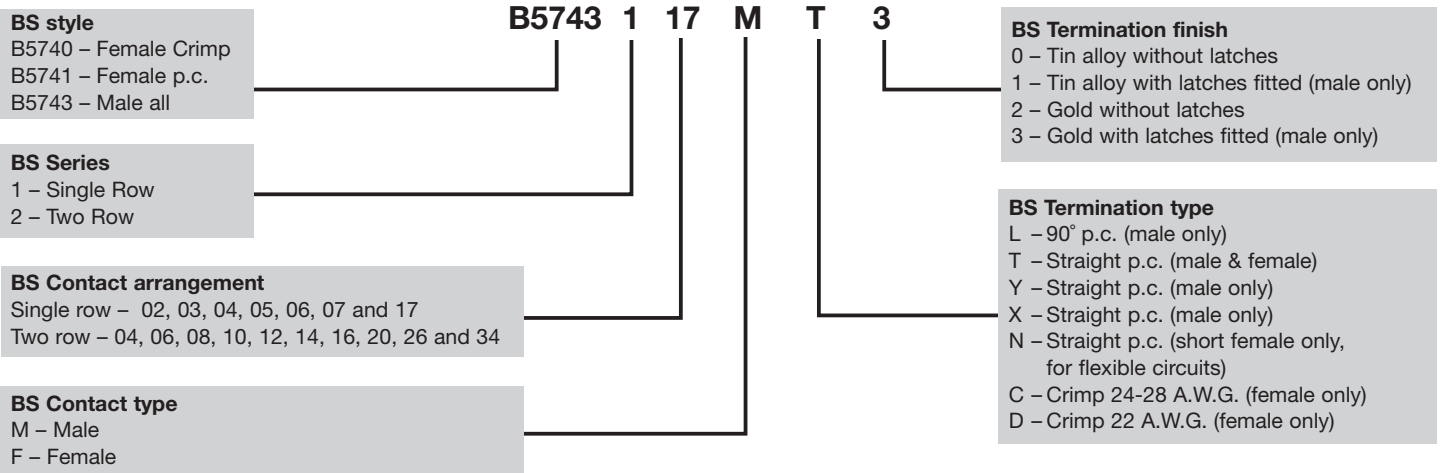

TOOL ORDERING INFORMATION

Hand Crimp Tool 8 Indent Die set . . . M22520/2-01 (BS Style 5310-3A-300)	Contact Insertion Tool MP6811 (BS Style T5748-19)
Connector Separating Tool T5746 (BS Style T5746)	Contact Withdrawal Tool MP6808
Retaining Strap MP6759	Crimp Tool Positioner MP6818 (BS Style T5747)

CONTACT ARRANGEMENT (viewed from mating face of male connector)



A comprehensive range

In addition to micronectors we supply a comprehensive range of connectors for a variety of applications including general industrial, I.T. and military.

Due to our policy of continuous product development, ITW McMurdo Connectors retain the right to change the specification at any time without prior notice. Designed & printed in the UK.

ITW McMurdo Connectors
Division of ITW Limited
Norway Road
Hilsea
Portsmouth
PO3 5HT
United Kingdom
Tel: 02392 656200
Fax: 02392 666352
e-mail: info@itwmcmurdo.co.uk
www.itwmcmurdo.co.uk

Tel: +44 (0)1962 773004
Fax: +44 (0)1962 773104

sales@in2connect.uk.com
<www.in2connect.uk.com>

