A close-up photograph of a green printed circuit board (PCB) populated with various electronic components. In the foreground, a white plastic connector strip is visible, featuring the 'ept' logo and the part number '103-60084 3751'. The PCB is densely packed with components, including numerous small blue and brown surface-mount components, several black integrated circuits, and various passive components. The background is slightly blurred, showing more of the board's layout.

Connectors
according to DIN 41612/IEC 60603-2

Technical specifications	80
Derating diagrams	81
Hole specifications	82
Technical information	83
Type B	84
Type B/2	88
Type B/3	92
Type C	96
Type C/2	100
Type C/3	104
Type M	108
Type M/2	112, 113
Type M/3	112, 113
Type R	114
Type R/2	118
Type R/3	122
Type D	126
Type E	129
Type F	132
Type F low profile	136
Type G	138, 140
Type G low profile	139
Type H11	142
Type H11 low profile	144
Type H15	145, 146
Type H15 low profile	147
Type H7/F24	148
Type H7/F24 low profile	150
Type VME 64x	152
Accessories: Shroud VME	153
Switching connector	154
IDC: Types B and C, technical specifications	156
Accessories: Shroud	158
Additional information: Board lock	159
Additional information: Coding	160
Additional information: Pre-mating/late-mating contacts	161
Fax request	162

Connectors according to DIN 41612/IEC 60603-2
Technical specifications

Technical specifications

Types according to IEC 60603-2		B, B/2, B/3	C, C/2, C/3	D	E	F	G	H		VME 64x	
Inverted type			R, R/2, R/3								
Maximum no. of contacts		64/32/20	96/48/30	32	48	48	64	11	15	160	
Contact row designation of male and female connectors		a b	a b c	a c	a c e	z b d	z b d f	b	z d	z a b c d a b c z d	
Operating temperature range		- 55 °C to + 125 °C						- 65 °C to + 125 °C		- 55 °C to + 125 °C	
Creepage (K) and clearance (L) in mm	Within a row	K	1.2 mm	3.0 mm	3.0 mm	3.0 mm	3.0 mm	8.0 mm	8.0 mm	1.2	1.0
		L	1.2 mm	3.0 mm	1.6 mm	1.6 mm	4.5 mm	4.5 mm	1.2	1.0	
	Between the rows	K	1.2 mm	3.0 mm	3.0 mm	3.0 mm	8.0 mm	8.0 mm	1.2	1.2	
		L	1.2 mm	3.0 mm	1.6 mm	1.6 mm	4.5 mm	4.5 mm	1.2	1.2	
Max. operating current at ambient temperature	I		See diagrams on page 81								
	+ 20 °C		1.5 A	5.6 A				15 A		1.5 A	
	+ 70 °C		1.1 A	4.0 A				11 A		1.1 A	
	+ 100 °C		0.7 A	2.5 A				8 A		0.7 A	
Test voltage, 50 Hz, 1 minute											
Contact/contact	V _{rms}	1000 V	1550 V	1550 V	1550 V	3100 V	1000 V				
Contact/ground	V _{rms}	1550 V	1550 V	2500 V	2500 V	3100 V	1550 V				
Contact resistance	R	< 20 mΩ	< 15 mΩ				< 8 mΩ		20 mΩ	< 30 mΩ	
Insulation resistance	R	> 10 ⁶ MΩ								10 ⁴ MΩ	
Durability according to DIN EN 60603-2	Performance level I = 500 mating cycles									500 mating cycles	
	Performance level II = 400 mating cycles									250 mating cycles	
	Performance level III = 50 mating cycles									-	
Engaging and separating force for the complete, fully equipped connector	F	64 contacts < 60 N 96 contacts < 90 N	< 40 N	< 60 N	< 75 N	< 100 N	< 80 N	< 90 N	160 N		
		32 contacts < 30 N 48 contacts < 45 N									
		20 contacts < 18 N 30 contacts < 28 N									
Separating force per contact (test measuring device)	F	> 0.15 N				> 0.2 N				> 0.15 N	
Design female contact	Double contact										
Insulator material	PBT glass filled, UL 94 V-0 PC fiber-glass reinforced, not combustible acc. to UL 94 V-1 PA glass filled, UL 94 V-0										
Environment/approvals	RoHS compliant/UL (file: E130314)										

*** Note on press-fit technology:**

Printed circuit boards with flame protection FR-4 or FR-6 are permissible up to a temperature of 115 °C. The press-fit standard IEC 352-5 only specifies the press-fit connection up to a working temperature of 85 °C. For working temperatures that exceed 85 °C, it is recommended that the press-fit connection is qualified application-specific by ept.

Derating diagrams

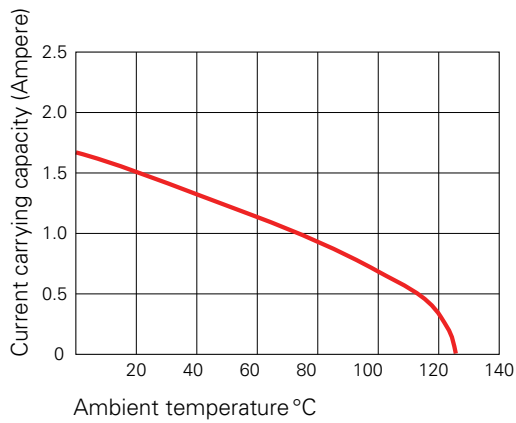

Type B, C, R

20 °C	1.5 A
70 °C	1.1 A
100 °C	0.7 A

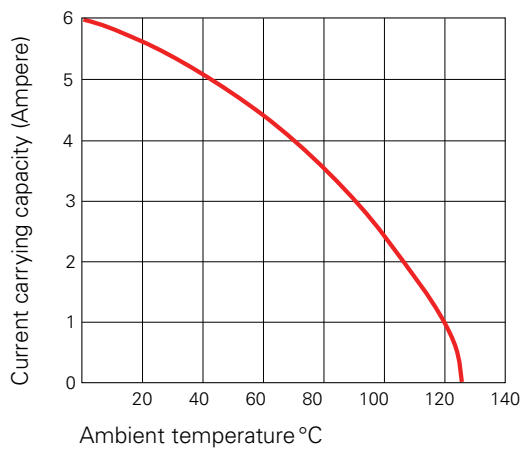

Type D, E, F, G

20 °C	5.6 A
70 °C	4.0 A
100 °C	2.5 A

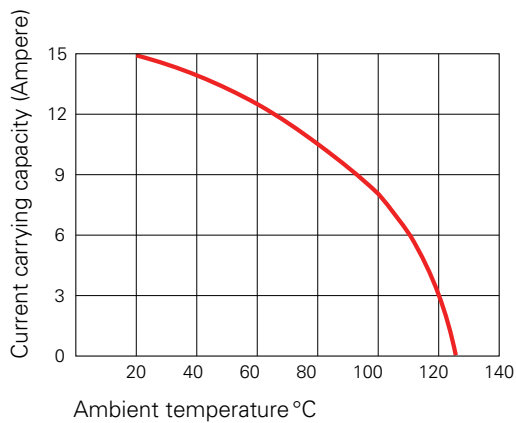

Type H11

20 °C	15 A
70 °C	11 A
100 °C	8 A

Hole specifications

Plated through-hole according to IEC 60352-5

ept offers adapted press-fit zones for various new board surfaces.

		C female connector Special version	B/C/R/M/F low profile/ G low profile/VME64x	D/E/F/G	
		Nominal hole	Ø 0.85 mm	Ø 1.0 mm	Ø 1.6 mm
imm. Sn printed circuit boards					
A	PCB thickness	min. 1.6 mm	min. 1.6 mm	min. 1.6 mm	
B	Plated hole	Ø 0.85 + 0.09/- 0.00 mm	Ø 1 + 0.09/- 0.00 mm	Ø 1.6 + 0.09/- 0.00 mm	
C	Drill hole	1.0 ± 0.025 mm	1.15 ± 0.025 mm	1.75 ± 0.025 mm	
D	Cu plating	min. 25 µm	min. 25 µm	min. 25 µm	
E	imm. Sn plating	max. 1.5 µm	max. 1.5 µm	max. 1.5 µm	
F	Annular ring	min. 0.1 mm	min. 0.1 mm	min. 0.1 mm	
Ni, Au printed circuit boards					
A	PCB thickness	min. 1.6 mm	min. 1.6 mm	min. 1.6 mm	
B	Plated hole	Ø 0.85 + 0.09/- 0.00 mm	Ø 1 + 0.09/- 0.00 mm	Ø 1.6 + 0.09/- 0.00 mm	
C	Drill hole	1.0 ± 0.025 mm	1.15 ± 0.025 mm	1.75 ± 0.025 mm	
D	Cu plating	min. 25 µm	min. 25 µm	min. 25 µm	
E	Ni, Au plating	0.05 – 0.2 µm Au more than 2.5 – 5 µm Ni	0.05 – 0.2 µm Au more than 2.5 – 5 µm Ni	0.05 – 0.2 µm Au more than 2.5 – 5 µm Ni	
F	Annular ring	min. 0.1 mm	min. 0.1 mm	min. 0.1 mm	
pure Cu printed circuit boards					
A	PCB thickness	min. 1.6 mm	min. 1.6 mm	min. 1.6 mm	
B	Plated hole	Ø 0.85 + 0.09/- 0.00 mm	Ø 1 + 0.09/- 0.04 mm	Ø 1.6 + 0.09/- 0.07 mm	
C	Drill hole	1.0 ± 0.025 mm	1.15 ± 0.025 mm	1.75 ± 0.025 mm	
D	Cu plating	min. 25 µm	min. 25 µm	min. 25 µm	
E	OSP*	e. g. GLICOAT-SMD (F2) with 0.12 – 0.15 µm	e. g. GLICOAT-SMD (F2) with 0.12 – 0.15 µm	e. g. GLICOAT-SMD (F2) with 0.12 – 0.15 µm	
F	Annular ring	min. 0.1 mm	min. 0.1 mm	min. 0.1 mm	
HAL Sn printed circuit boards					
A	PCB thickness	min. 1.6 mm	min. 1.6 mm	min. 1.6 mm	
B	Plated hole	Ø 0.85 + 0.09/- 0.02 mm	Ø 1 + 0.09/- 0.06 mm	Ø 1.6 ± 0.09 mm	
C	Drill hole	1.0 ± 0.025 mm	1.15 ± 0.025 mm	1.75 ± 0.025 mm	
D	Cu plating	min. 25 µm	min. 25 µm	min. 25 µm	
E	HAL Sn	5 – 15 µm	5 – 15 µm	5 – 15 µm	
F	Annular ring	min. 0.1 mm	min. 0.1 mm	min. 0.1 mm	

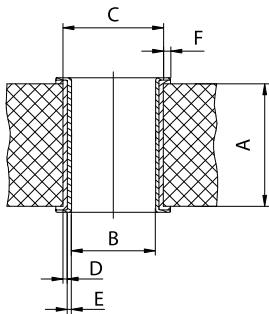

* OSP = Organic Solderability Preservatives

Technical information

For connectors according to DIN 41612/IEC 60603-2 (DIN connectors), ept offers three Tcom press® press-fit zone variants for different printed circuit board thicknesses.

Part numbers key

Type	PCB thickness 1.5 to 2.0 mm	PCB thickness 2.0 to 2.8 mm	PCB thickness > 2.8 mm
B, B/2, B/3 (female connectors)	102-xxxxx-01	102-xxxxx-02	102-xxxxx-03
C, C/2, C/3 (female connectors)	104-xxxxx-01	104-xxxxx-02	104-xxxxx-03

Hole diameter 0.85 mm

In addition to the 1.0 standard hole, for the DIN types B and C female connectors a Tcom press® press-fit zone for the 0.85 mm hole is available. This provides more space between two plated-through holes and there can be an additional circuit between the drill holes.



Tcom press® 1.0 mm/0.85 mm

Part numbers key for 0.85 mm Tcom press® on request

Type	Part number
B, B/2, B/3 (female connectors)	002-xxxxx-xx
C, C/2, C/3 (female connectors)	004-xxxxx-xx

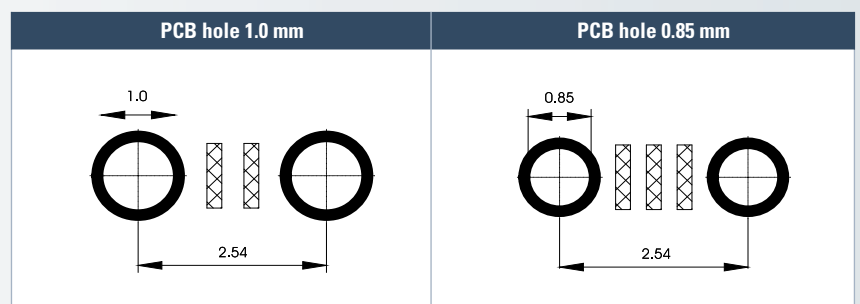

Connectors according to DIN 41612 / IEC 60603-2

Type B

Male connector

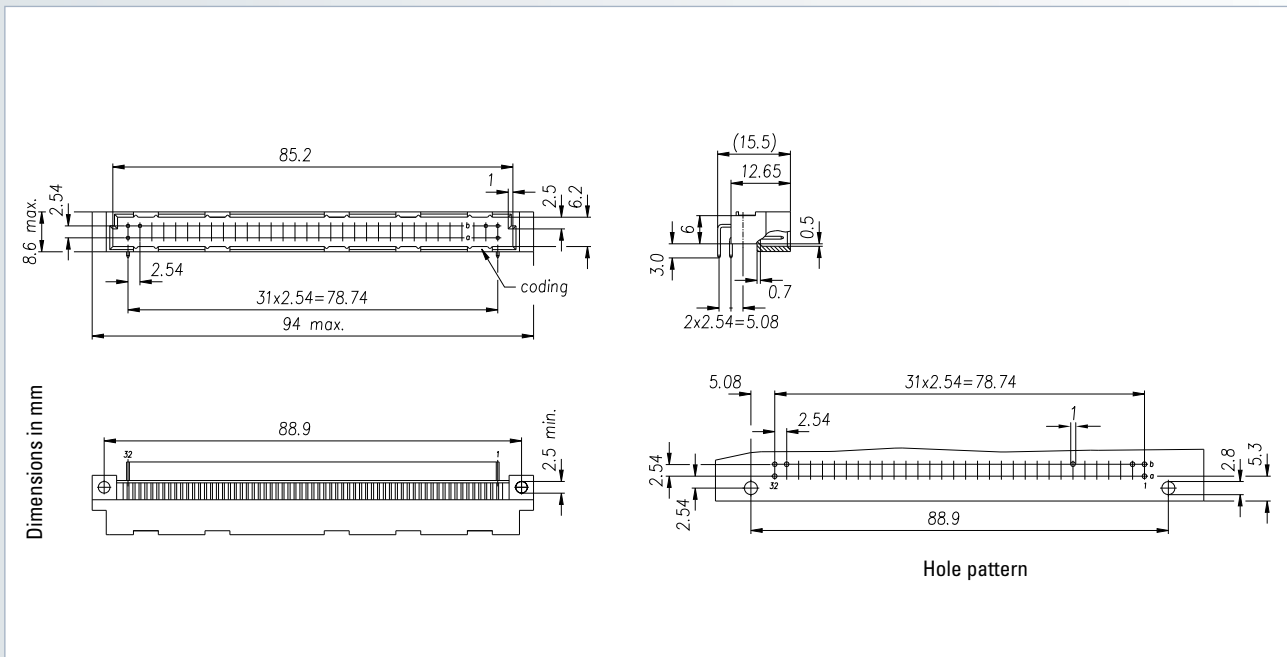

No. of contacts	Contact arrangement	Press-fit technology – Performance level II	
		Termination length	
Part number			
32		101-60004	101-65005
32		101-60014	101-65015
64		101-60064	101-65065

<p>Accessories</p> <ul style="list-style-type: none"> – Press-fit tool (see page 206) – Support tool (see page 207) – Coding accessories (see page 160) 	<p>On request</p> <ul style="list-style-type: none"> – Performance levels I + III or customer-specific – Special contact length 	<p>Options</p> <ul style="list-style-type: none"> – Contact arrangement (see page 162)
<p>Note</p> <ul style="list-style-type: none"> – * Rear mating zone performance level II 		

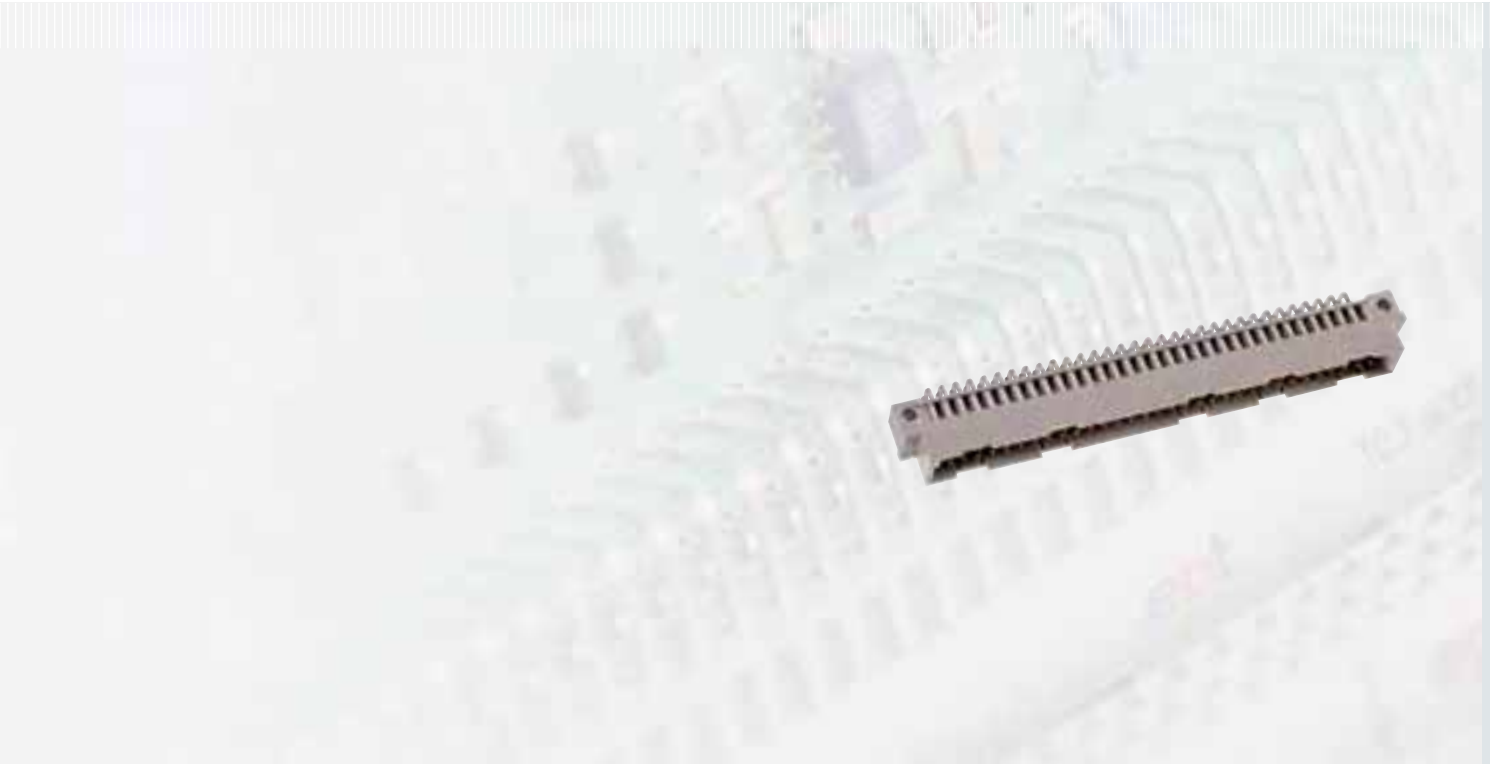

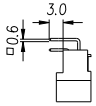
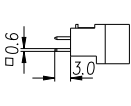
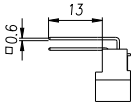
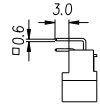
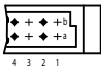
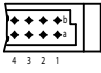
No. of contacts	Contact arrangement	Solder technology Performance level II			THTR*
		Termination length			
					
Part number					
32		101-40024	101-40025	101-40044	101-40024TH
64		101-40064	101-40065	101-40074	101-40064TH

<p>Accessories</p> <ul style="list-style-type: none"> - Coding accessories (see page 160) 	<p>On request</p> <ul style="list-style-type: none"> - Performance levels I + III or customer-specific - Special contact length - Other termination lengths in THTR 	<p>Options</p> <ul style="list-style-type: none"> - Board lock (see page 159) - Contact arrangement (see page 162)
<p>Note</p> <ul style="list-style-type: none"> - * THTR (Through Hole Technology Reflow) 		

Connectors according to DIN 41612 / IEC 60603-2

Type B

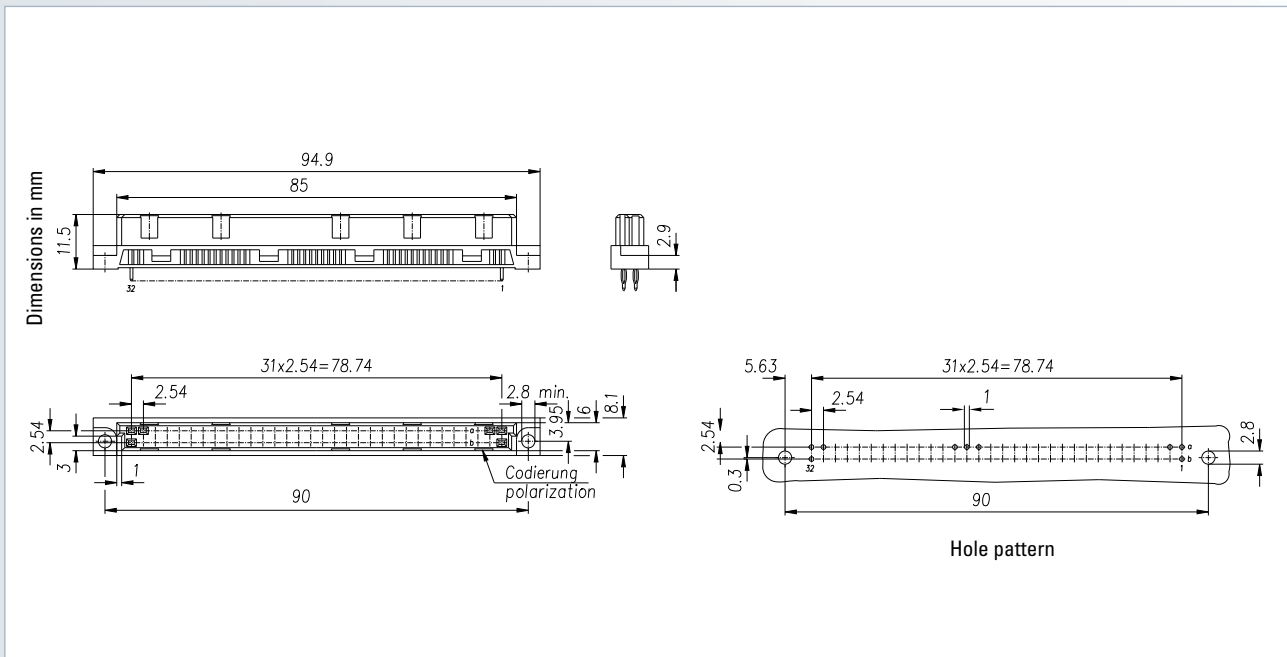

Female connector

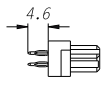
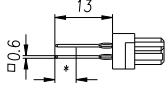
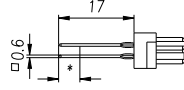
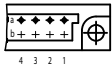
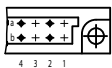
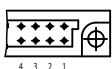

No. of contacts	Contact arrangement	Press-fit technology – Performance level II		
		Termination length		
				
Part number				
32		302-63014-02	302-65015-03	302-65016-04
32		102-63024-xx	102-65025-xx	102-65026-xx
64		302-63064-02	302-65065-03	302-65066-04

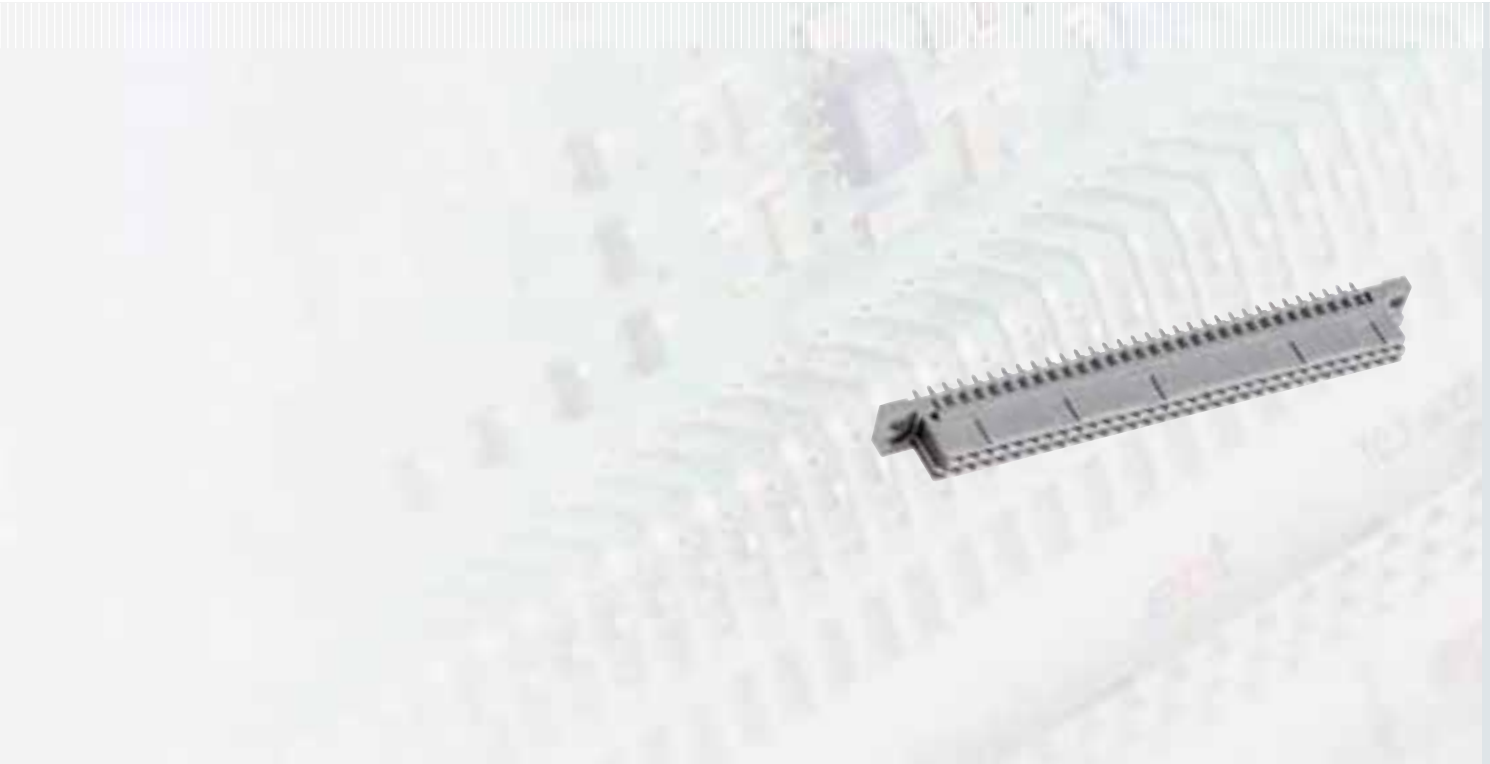
Accessories <ul style="list-style-type: none"> – Press-fit tool (see page 208) – Support tool (see page 209) – Coding accessories (see page 160) 	On request <ul style="list-style-type: none"> – Performance levels I + III or customer-specific – Special contact length – Alternative surface Sn, e.g. for WireWrap 	Options <ul style="list-style-type: none"> – Without flange – Contact arrangement (see page 162)
Note <ul style="list-style-type: none"> – * Rear mating zone performance level II 	Ordering note <ul style="list-style-type: none"> Only for 102 – PCB 1.5 to 2.0 mm = xxx-xxxx-01 with termination length = 3.2 mm – PCB 2.0 to 2.8 mm = xxx-xxxx-02 with termination length = 4.6 mm – PCB > 2.8 mm = xxx-xxxx-03 with termination length = 4.6 mm 	Cross reference <ul style="list-style-type: none"> – Type B with IDC (see page 156)

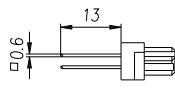
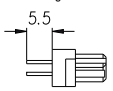
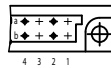
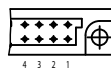

No. of contacts	Contact arrangement	Solder technology – Performance level II				
		Termination length				
						Manual soldering with solder lug 
Part number						
32		102-40024	–	–	102-40026	102-40044
64		302-40064-05 in THTR* 302-40064-05TH	302-40064-01 in THTR* 302-40064-01TH	302-40064-02 in THTR* 302-40064-02TH	302-40065-03	102-40074

Accessories – Coding accessories (see page 160)	On request – Performance levels I + III or customer-specific – Special contact length – Other termination lengths in THTR	Options – Board lock (see page 159) – Contact arrangement (see page 162)
Cross reference – Type B with IDC (see page 156)	Note – * THTR (Through Hole Technology Reflow)	

Connectors according to DIN 41612 / IEC 60603-2

Type B/2

Male connector

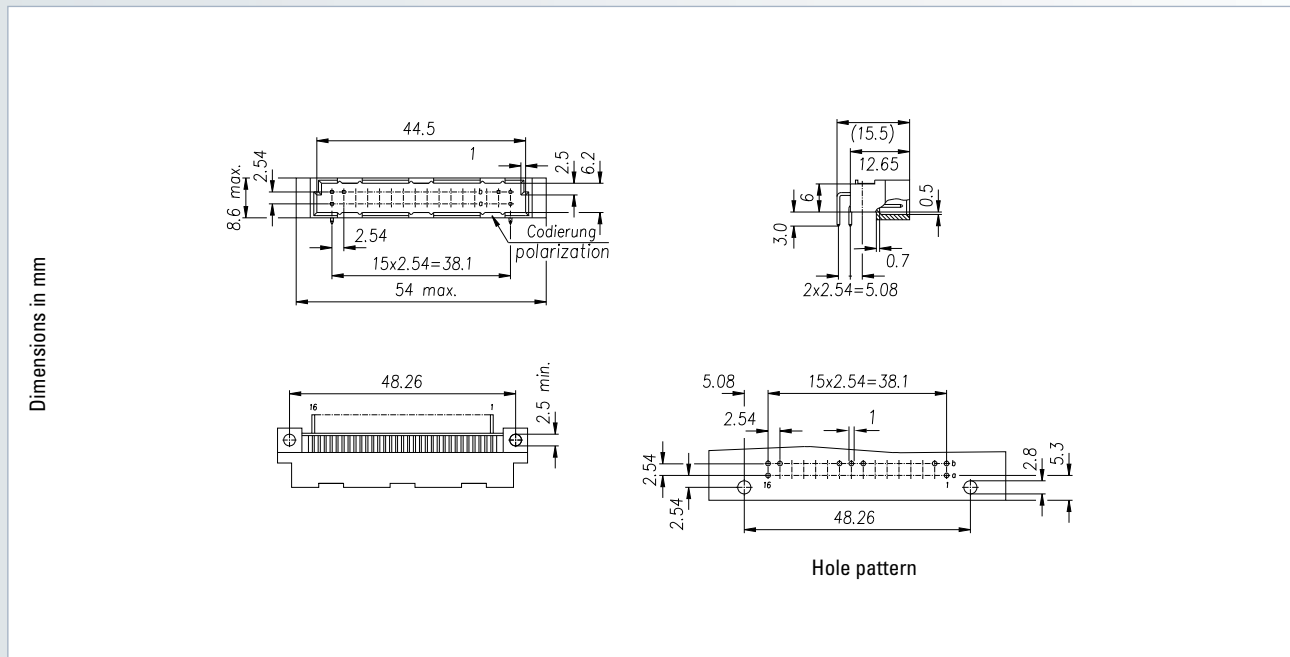

No. of contacts	Contact arrangement	Press-fit technology – Performance level II	
		Termination length	
Part number			
16		101-69004	101-79006
32		101-69014	101-79016

<p>Accessories</p> <ul style="list-style-type: none"> – Press-fit tool (see page 206) – Support tool (see page 207) – Coding accessories (see page 160) 	<p>On request</p> <ul style="list-style-type: none"> – Performance levels I + III or customer-specific – Special contact length 	<p>Options</p> <ul style="list-style-type: none"> – Contact arrangement (see page 162)
<p>Note</p> <ul style="list-style-type: none"> – * Rear mating zone performance level II 		

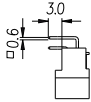
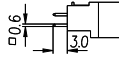
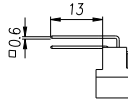
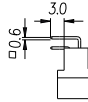
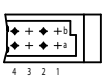
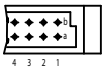

No. of contacts	Contact arrangement	Solder technology Performance level II			THTR*
		Termination length			
					
Part number					
16		101-90004	101-90115	101-90006	101-90004TH
32		101-90014	101-90105	101-90016	101-90014TH



<p>Accessories</p> <ul style="list-style-type: none"> - Coding accessories (see page 160) 	<p>On request</p> <ul style="list-style-type: none"> - Performance levels I + III or customer-specific - Special contact length - Other termination lengths in THTR 	<p>Options</p> <ul style="list-style-type: none"> - Board lock (see page 159) - Contact arrangement (see page 162)
<p>Note</p> <ul style="list-style-type: none"> - * THTR (Through Hole Technology Reflow) 		

Connectors according to DIN 41612 / IEC 60603-2

Type B/2

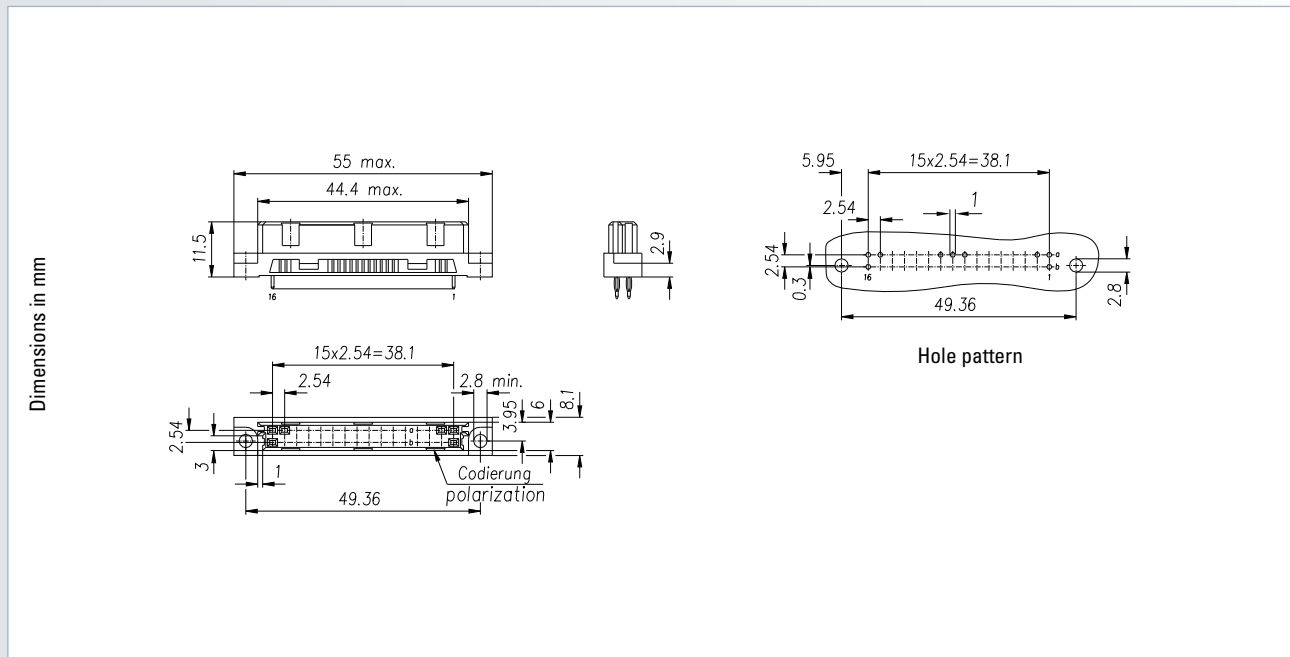

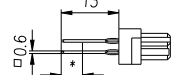
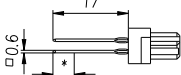
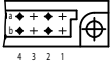
Female connector



No. of contacts	Contact arrangement	Press-fit technology – Performance level II		
		Termination length		
				
Part number				
16		102-69004-xx	102-79006-xx	102-79106-xx
32		102-69064-xx	102-79066-xx	102-79166-xx

Accessories <ul style="list-style-type: none"> – Press-fit tool (see page 208) – Support tool (see page 209) – Coding accessories (see page 160) 	On request <ul style="list-style-type: none"> – Performance levels I + III or customer-specific – Special contact length – Alternative surface Sn, e.g. for WireWrap 	Options <ul style="list-style-type: none"> – Without flange – Contact arrangement (see page 162)
Note <ul style="list-style-type: none"> – * Rear mating zone performance level II 	Ordering note <ul style="list-style-type: none"> – PCB 1.5 to 2.0 mm = xxx-xxxx-01 with termination length = 3.2 mm – PCB 2.0 to 2.8 mm = xxx-xxxx-02 with termination length = 4.6 mm – PCB > 2.8 mm = xxx-xxxx-03 with termination length = 4.6 mm 	

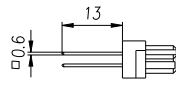
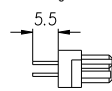
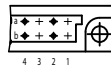
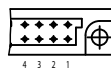

No. of contacts	Contact arrangement	Solder technology – Performance level II			
		Termination length			
					Manual soldering with solder lug 
Part number					
16		102-90004	102-90005	102-90006	102-90025
32		102-90064	102-90065	102-90066	102-90075

<p>Accessories</p> <ul style="list-style-type: none"> – Coding accessories (see page 160) 	<p>On request</p> <ul style="list-style-type: none"> – Performance levels I + III or customer-specific – Also in THTR 	<p>Options</p> <ul style="list-style-type: none"> – Board lock (see page 159) – Contact arrangement (see page 162)
---	--	---

Connectors according to DIN 41612 / IEC 60603-2

Type B/3

Male connector

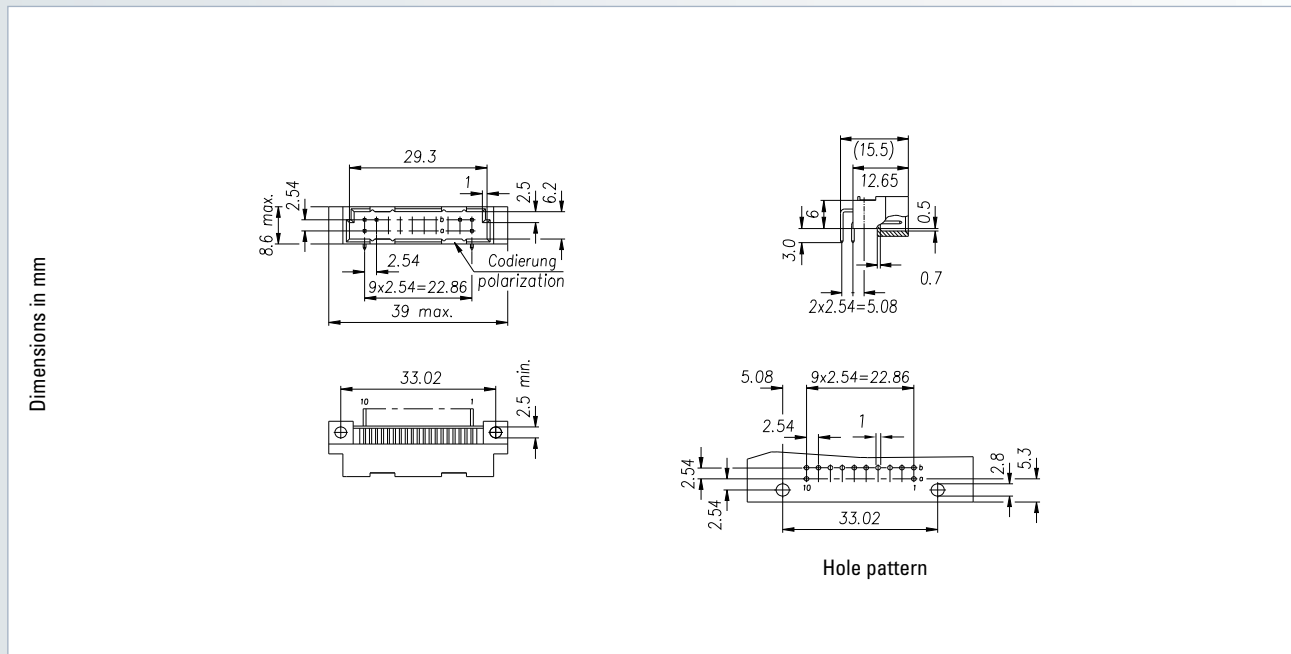

No. of contacts	Contact arrangement	Press-fit technology – Performance level II	
		Termination length	
Part number			
20		101-68014	101-78016

<p>Accessories</p> <ul style="list-style-type: none"> – Press-fit tool (see page 206) – Support tool (see page 207) – Coding accessories (see page 160) 	<p>On request</p> <ul style="list-style-type: none"> – Performance levels I + III or customer-specific – Special contact length 	<p>Options</p> <ul style="list-style-type: none"> – Contact arrangement (see page 162)
<p>Note</p> <ul style="list-style-type: none"> – * Rear mating zone performance level II 		



No. of contacts	Contact arrangement	Solder technology – Performance level II		
		Termination length		
Part number				
10		101-80004	101-80105	101-80006
20		101-80014	101-80115	101-80016



<p>Accessories</p> <ul style="list-style-type: none"> – Coding accessories (see page 160) 	<p>On request</p> <ul style="list-style-type: none"> – Performance levels I + III or customer-specific – Special contact length – Also in THTR 	<p>Options</p> <ul style="list-style-type: none"> – Board lock (see page 159) – Contact arrangement (see page 162)
---	--	---

Connectors according to DIN 41612 / IEC 60603-2

Type B/3

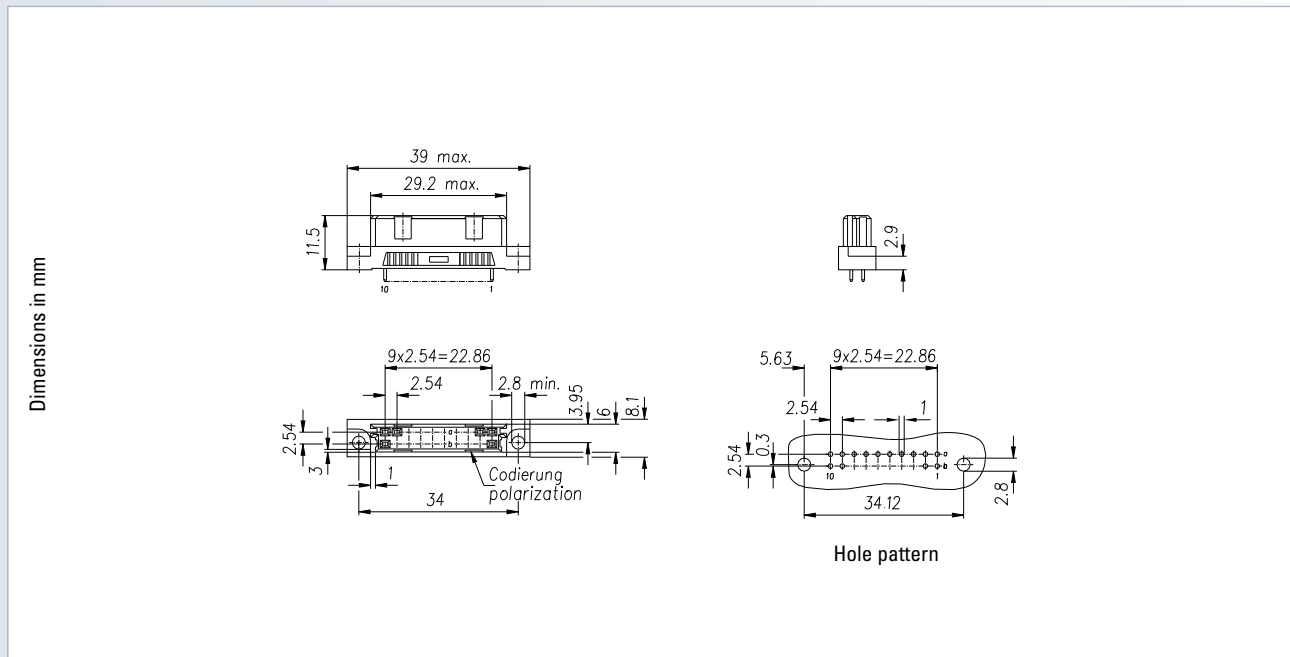

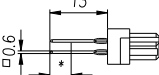
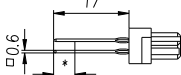
Female connector



No. of contacts	Contact arrangement	Press-fit technology – Performance level II		
		Termination length		
				
Part number				
20		102-68014-xx	102-78016-xx	102-78116-xx

Accessories <ul style="list-style-type: none"> – Press-fit tool (see page 208) – Support tool (see page 209) – Coding accessories (see page 160) 	On request <ul style="list-style-type: none"> – Performance levels I + III or customer-specific – Special contact length – Alternative surface Sn, e. g. for WireWrap 	Options <ul style="list-style-type: none"> – Without flange – Contact arrangement (see page 162)
Note <ul style="list-style-type: none"> – * Rear mating zone performance level II 	Ordering note <ul style="list-style-type: none"> – PCB 1.5 to 2.0 mm = xxx-xxxx-01 with termination length = 3.2 mm – PCB 2.0 to 2.8 mm = xxx-xxxx-02 with termination length = 4.6 mm – PCB > 2.8 mm = xxx-xxxx-03 with termination length = 4.6 mm 	

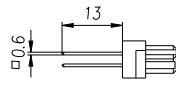
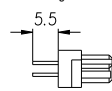
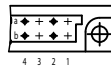
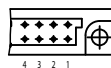

No. of contacts	Contact arrangement	Solder technology – Performance level II			
		Termination length			
					Manual soldering with solder lug 
Part number					
10		102-80004	102-80005	102-80006	102-80025
20		102-80064	102-80065	102-80066	102-80075



<p>Accessories</p> <ul style="list-style-type: none"> – Coding accessories (see page 160) 	<p>On request</p> <ul style="list-style-type: none"> – Performance levels I + III or customer-specific – Special contact length – Also in THTR 	<p>Options</p> <ul style="list-style-type: none"> – Board lock (see page 159) – Contact arrangement (see page 162)
---	--	---

Connectors according to DIN 41612 / IEC 60603-2

Type C

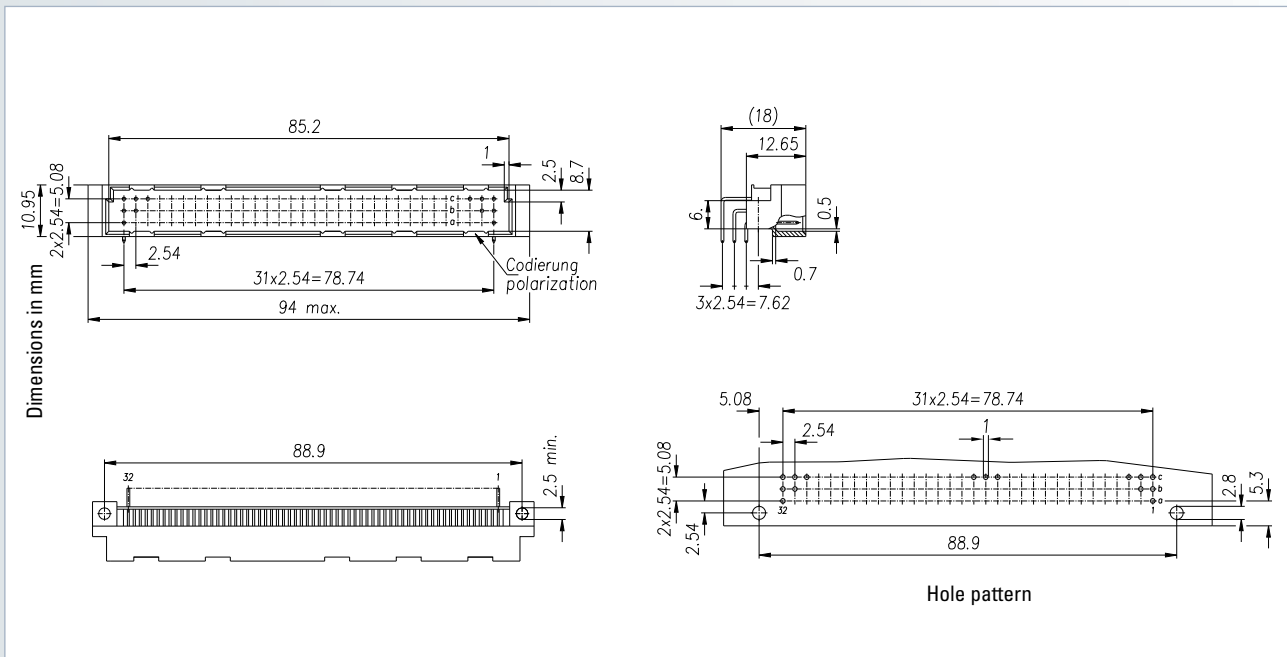
Male connector

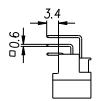
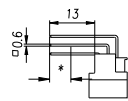
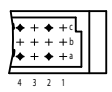
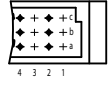
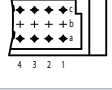

No. of contacts	Contact arrangement	Press-fit technology – Performance level II	
		Termination length	
			
Part number			
32		103-60014	103-65015
48		103-60044	103-65045
64		103-60054	103-65055
96		103-60064	103-65065

<p>Accessories</p> <ul style="list-style-type: none"> – Press-fit tool (see page 206) – Support tool (see page 207) – Coding accessories (see page 160) 	<p>On request</p> <ul style="list-style-type: none"> – Performance levels I + III or customer-specific – Special contact length 	<p>Options</p> <ul style="list-style-type: none"> – Contact arrangement (see page 162)
<p>Note</p> <ul style="list-style-type: none"> – * Rear mating zone performance level II 		

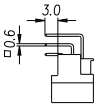
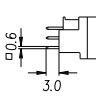
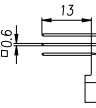
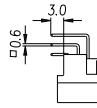
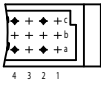
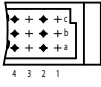
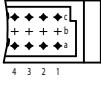
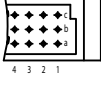

No. of contacts	Contact arrangement	Solder technology Performance level II			THTR*
		Termination length			
					
Part number					
32		103-40014	103-40015	103-40194	103-40014TH
48		103-40024	103-40025	103-40144	103-40024TH
64		103-40034	103-40035	103-40154	103-40034TH
96		103-40064	103-40065	103-40174	103-40064TH

<p>Accessories</p> <ul style="list-style-type: none"> – Coding accessories (see page 160) 	<p>On request</p> <ul style="list-style-type: none"> – Performance levels I + III or customer-specific – Special contact length – Other termination lengths in THTR 	<p>Options</p> <ul style="list-style-type: none"> – Board lock (see page 159) – Contact arrangement (see page 162)
<p>Note</p> <ul style="list-style-type: none"> – * THTR (Through Hole Technology Reflow) 		

Connectors according to DIN 41612 / IEC 60603-2

Type C

Female connector

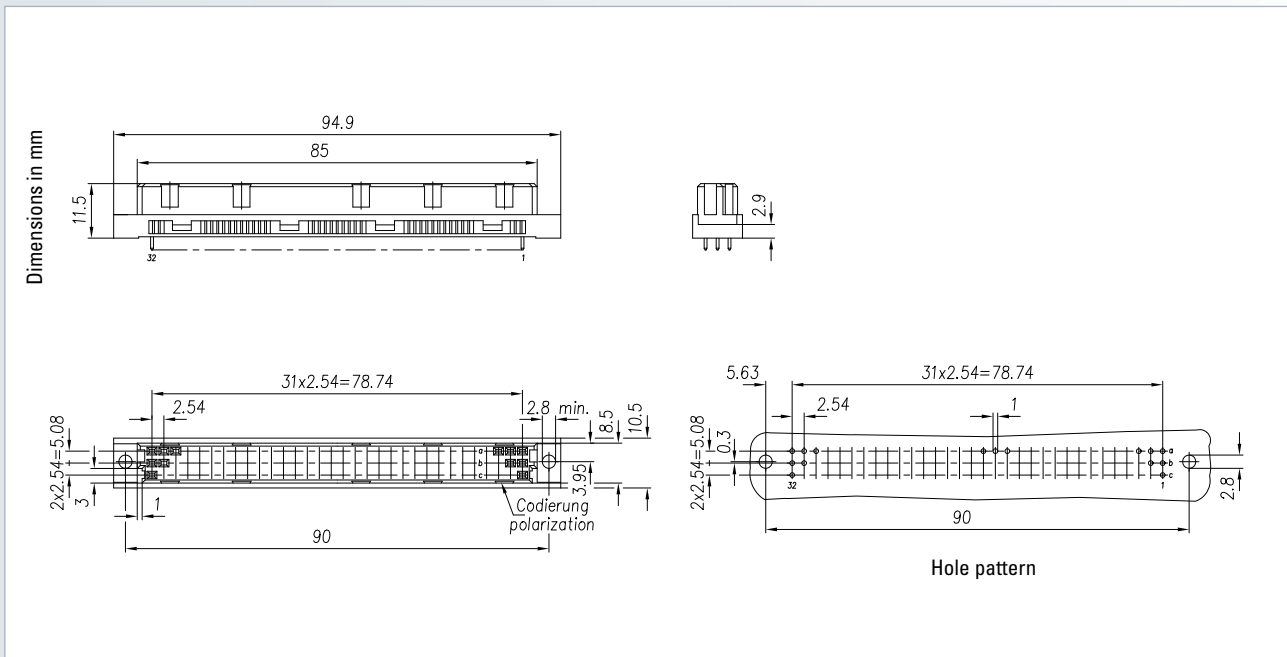

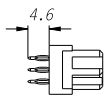
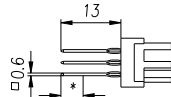
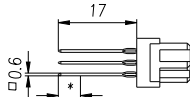
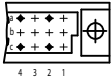
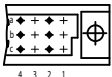
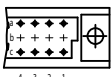
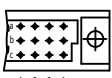
No. of contacts	Contact arrangement	Press-fit technology – Performance level II		
		Termination length		
				
Part number				
32		104-60014-xx	104-65015-xx	104-65016-xx
48		104-60044-xx	104-65045-xx	104-65046-xx
64		304-60054-02	304-65055-03	304-65056-04
96		304-60064-02	304-65065-03	304-65066-04





Note
– * Rear mating zone performance level II

Options
– Without flange
– Contact arrangement (see page 162)

Cross reference
– Type C with switching function (see page 155)
– VMEx (see page 152)
– Type C with IDC (see page 157)

<p>Accessories</p> <ul style="list-style-type: none"> – Press-fit tool (see page 208) – Support tool (see page 209) – Coding accessories (see page 160) – Shroud (see page 158) 	<p>On request</p> <ul style="list-style-type: none"> – Performance levels I + III or customer-specific – Special contact length – Alternative surface Sn, e. g. for WireWrap 	<p>Ordering note</p> <p>Only for 104</p> <ul style="list-style-type: none"> – PCB 1.5 to 2.0 mm = xxx-xxxx-01 with termination length = 3.2 mm – PCB 2.0 to 2.8 mm = xxx-xxxx-02 with termination length = 4.6 mm – PCB > 2.8 mm = xxx-xxxx-03 with termination length = 4.6 mm
--	--	--

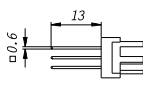

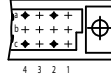
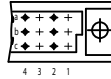
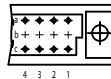
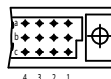
No. of contacts	Contact arrangement	Solder technology – Performance level II				
		Termination length				
						
Part number						
32		104-40014	–	–	104-40016	–
48		104-40044	–	–	104-40046	–
64		304-40054-05 in THTR* 304-40054-05TH	304-40054-01 in THTR* 304-40054-01TH	304-40054-02 in THTR* 304-40054-02TH	304-40055-03	104-40115
96		304-40064-05 in THTR* 304-40064-05TH	304-40064-01 in THTR* 304-40064-01TH	304-40064-02 in THTR* 304-40064-02TH	304-40065-03	104-40075

Accessories – Coding accessories (see page 160)	On request – Performance levels I + III or customer-specific – Special contact length – Other termination lengths in THTR	Options – Board lock (see page 159) – Contact arrangement (see page 162)
Cross reference – Type C with switching function (see page 155) – VMEx (see page 152) – Type C with IDC (see page 157)	Note – * THTR (Through Hole Technology Reflow)	

Connectors according to DIN 41612 / IEC 60603-2

Type C/2

Male connector

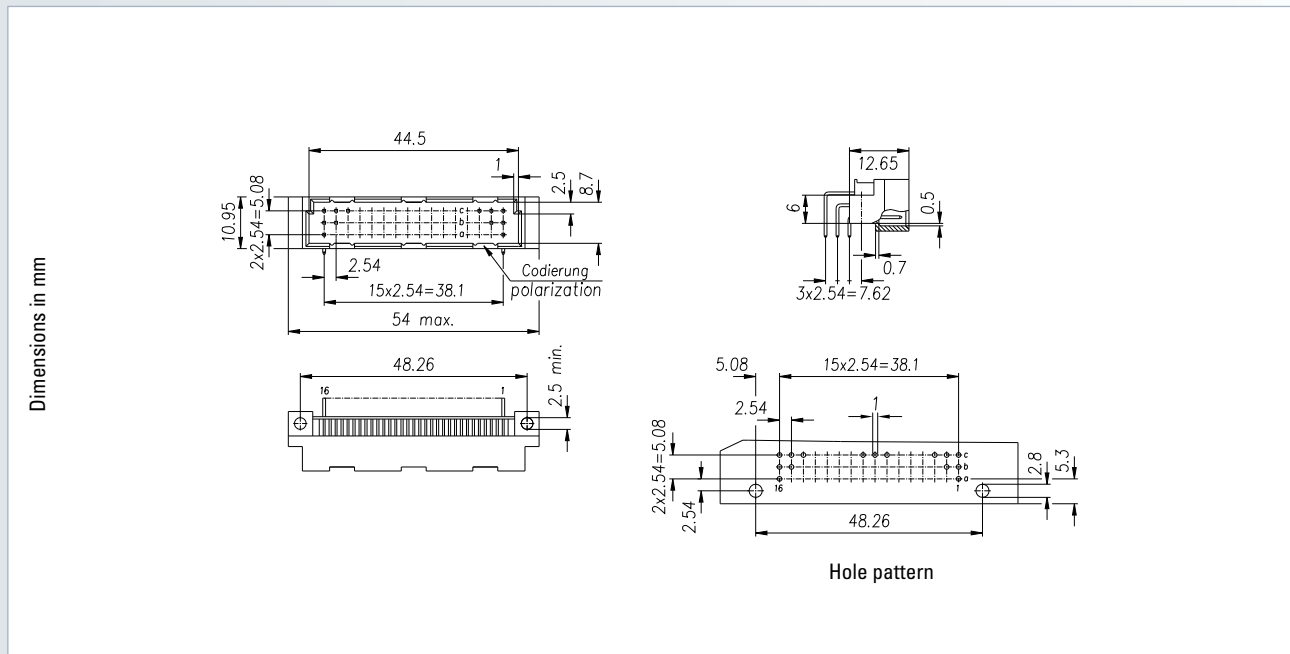

No. of contacts	Contact arrangement	Press-fit technology – Performance level II	
		Termination length	
Part number			
16		103-69004	103-79006
32		103-69014	103-79016
48		103-69064	103-79066

Accessories <ul style="list-style-type: none"> – Press-fit tool (see page 206) – Support tool (see page 207) – Coding accessories (see page 160) 	On request <ul style="list-style-type: none"> – Performance levels I + III or customer-specific – Special contact length 	Options <ul style="list-style-type: none"> – Contact arrangement (see page 162)
Note <ul style="list-style-type: none"> – * Rear mating zone performance level II 		

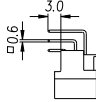
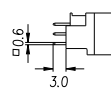
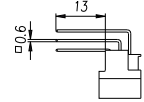
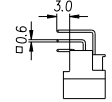
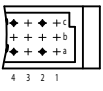
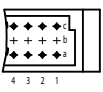
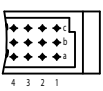

No. of contacts	Contact arrangement	Solder technology Performance level II			THTR*
		Termination length			Performance level II
					
Part number					
16		103-90004	103-90105	103-90006	103-90004TH
32		103-90014	103-90115	103-90016	103-90014TH
48		103-90064	103-90165	103-90066	103-90064TH

<p>Accessories</p> <ul style="list-style-type: none"> - Coding accessories (see page 160) 	<p>On request</p> <ul style="list-style-type: none"> - Performance levels I + III or customer-specific - Special contact length - Other termination lengths in THTR 	<p>Options</p> <ul style="list-style-type: none"> - Board lock (see page 159) - Contact arrangement (see page 162)
<p>Note</p> <ul style="list-style-type: none"> - * THTR (Through Hole Technology Reflow) 		

Connectors according to DIN 41612 / IEC 60603-2

Type C/2



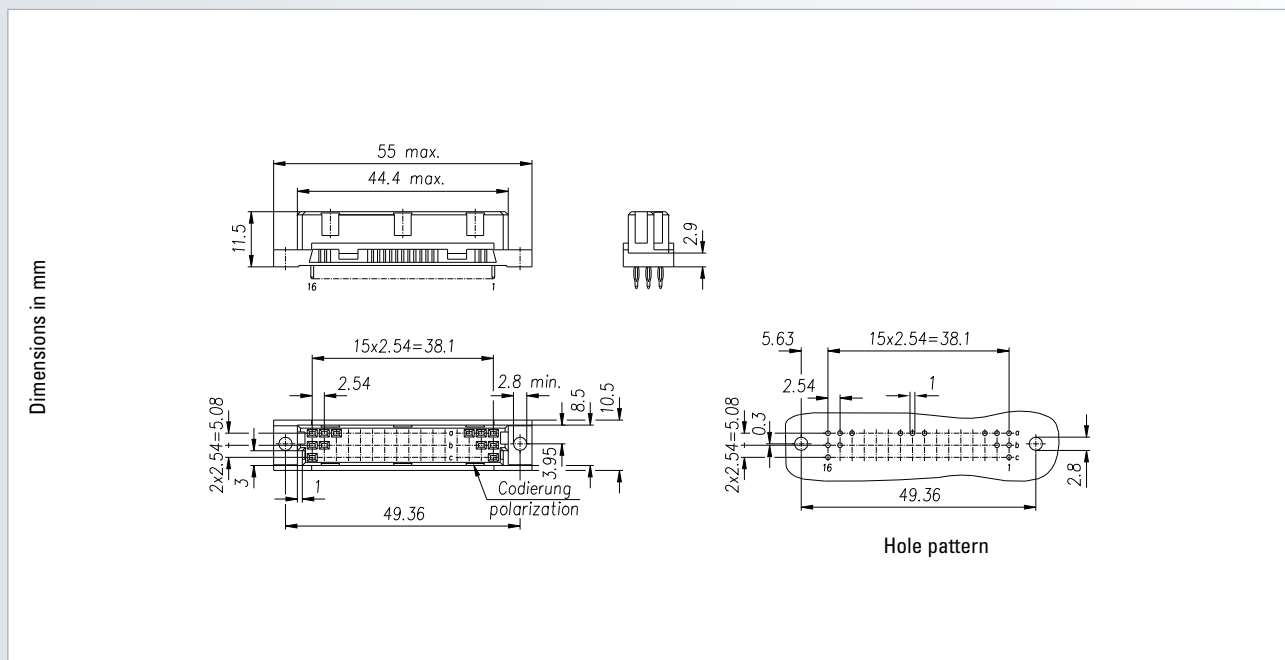

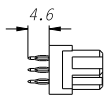
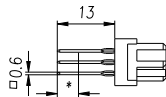
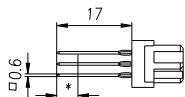
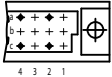
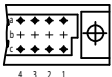
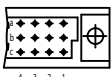
Female connector



No. of contacts	Contact arrangement	Press-fit technology – Performance level II		
		Termination length		
				
Part number				
16		104-69004-xx	104-79006-xx	104-79106-xx
32		304-69014-02	304-79016-03	304-79116-04
48		304-69064-02	304-79066-03	304-79166-04

Accessories – Press-fit tool (see page 208) – Support tool (see page 209) – Coding accessories (see page 160)	On request – Performance levels I + III or customer-specific – Special contact length – Alternative surface Sn, e. g. for WireWrap	Options – Without flange – Contact arrangement (see page 162)
Note – * Rear mating zone performance level II	Ordering note Only for 104 – PCB 1.5 to 2.0 mm = xxx-xxxx-01 with termination length = 3.2 mm – PCB 2.0 to 2.8 mm = xxx-xxxx-02 with termination length = 4.6 mm – PCB > 2.8 mm = xxx-xxxx-03 with termination length = 4.6 mm	

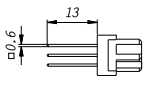

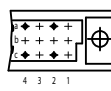
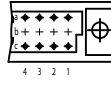
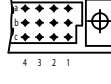
No. of contacts	Contact arrangement	Solder technology – Performance level II				
		Termination length				
						
Part number						
16		104-90004	–	–	104-90006	104-90025
32		304-90014-05	304-90014-01	304-90014-02	304-90016-03	104-90035
48		304-90064-05	304-90064-01	304-90064-02	304-90066-03	104-90075

<p>Accessories</p> <ul style="list-style-type: none"> – Coding accessories (see page 160) 	<p>On request</p> <ul style="list-style-type: none"> – Performance levels I + III or customer-specific – Special contact length – Also in THTR 	<p>Options</p> <ul style="list-style-type: none"> – Board lock (see page 159) – Contact arrangement (see page 162)
---	--	---

Connectors according to DIN 41612 / IEC 60603-2

Type C/3

Male connector

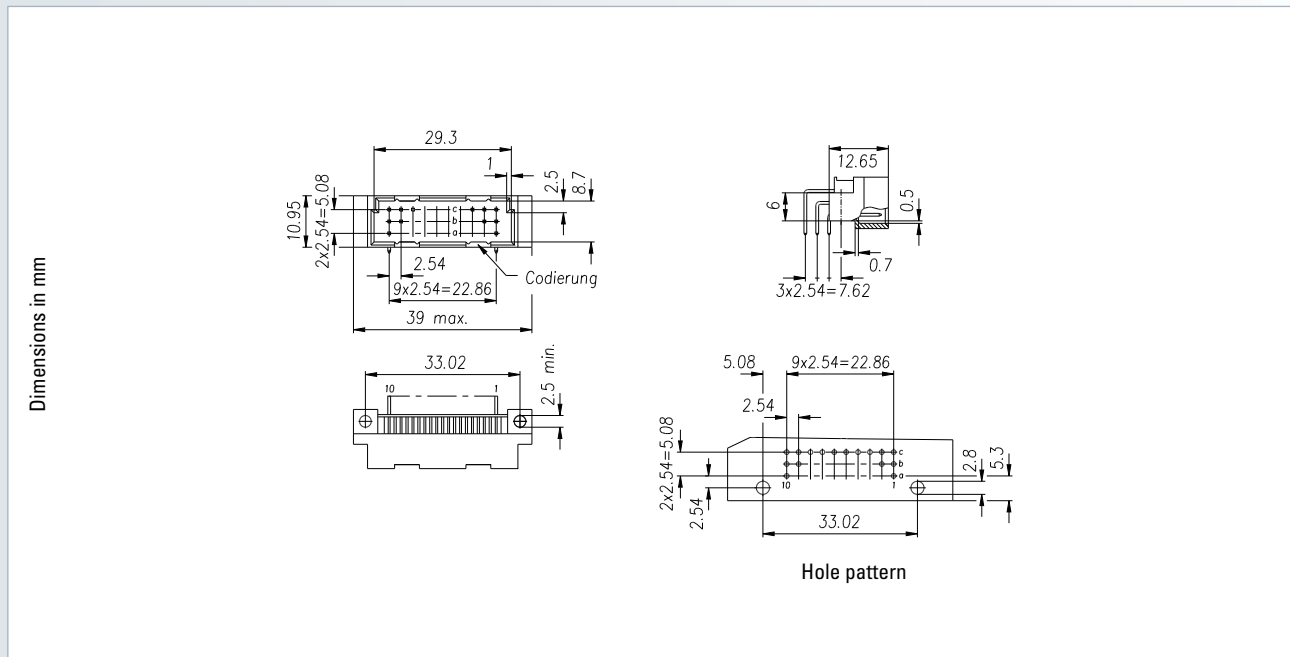

No. of contacts	Contact arrangement	Press-fit technology – Performance level II	
		Termination length	
Part number			
20		103-68004	103-78006
30		103-68014	103-78016

<p>Accessories</p> <ul style="list-style-type: none"> – Press-fit tool (see page 206) – Support tool (see page 207) – Coding accessories (see page 160) 	<p>On request</p> <ul style="list-style-type: none"> – Performance levels I + III or customer-specific – Special contact length 	<p>Options</p> <ul style="list-style-type: none"> – Without flange – Contact arrangement (see page 162)
<p>Note</p> <ul style="list-style-type: none"> – * Rear mating zone performance level II 		

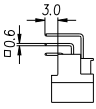
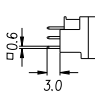
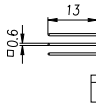
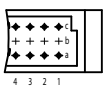
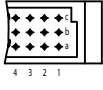

No. of contacts	Contact arrangement	Solder technology – Performance level II		
		Termination length		
				
Part number				
20		103-80014	103-80255	103-80016
30		103-80004	103-80265	103-80006

<p>Accessories</p> <ul style="list-style-type: none"> – Coding accessories (see page 160) 	<p>On request</p> <ul style="list-style-type: none"> – Performance levels I + III or customer-specific – Special contact length – Also in THTR 	<p>Options</p> <ul style="list-style-type: none"> – Board lock (see page 159) – Contact arrangement (see page 162)
---	--	---

Connectors according to DIN 41612 / IEC 60603-2

Type C/3



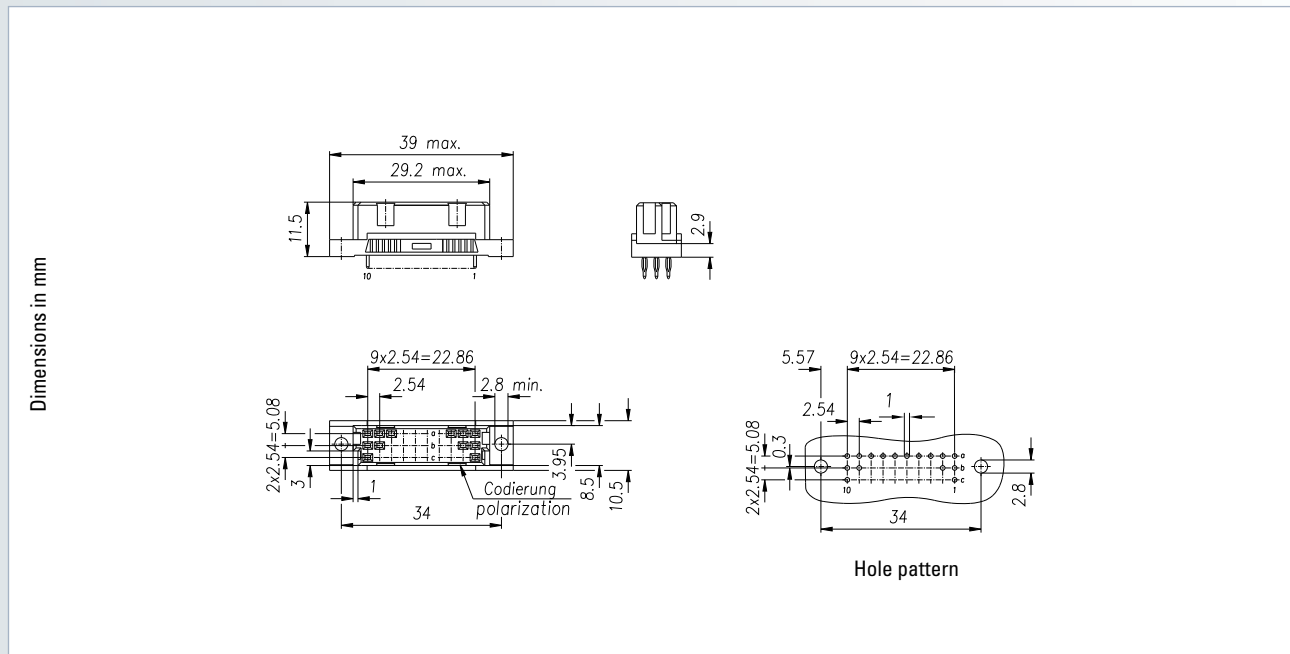

Female connector



No. of contacts	Contact arrangement	Press-fit technology – Performance level II		
		Termination length		
Part number				
20		304-68004-02	304-78006-03	304-78106-04
30		304-68014-02	304-78016-03	304-78116-04

Accessories <ul style="list-style-type: none"> – Press-fit tool (see page 208) – Support tool (see page 209) – Coding accessories (see page 160) 	On request <ul style="list-style-type: none"> – Performance levels I + III or customer-specific – Special contact length – Alternative surface Sn, e.g. for WireWrap 	Options <ul style="list-style-type: none"> – Without flange – Contact arrangement (see page 162)
Note <ul style="list-style-type: none"> – * Rear mating zone performance level II 		

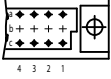
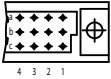

No. of contacts	Contact arrangement	Solder technology – Performance level II				
		Termination length				
						Manual soldering with solder lug 
Part number						
20		304-80014-05	304-80014-01	304-80014-02	304-80016-03	104-80035
30		304-80064-05	304-80064-01	304-80064-02	304-80066-03	104-80075

<p>Accessories</p> <ul style="list-style-type: none"> – Coding accessories (see page 160) 	<p>On request</p> <ul style="list-style-type: none"> – Performance levels I + III or customer-specific – Special contact length – Also in THTR 	<p>Options</p> <ul style="list-style-type: none"> – Board lock (see page 159) – Contact arrangement (see page 162)
---	--	---

Connectors according to DIN 41612 / IEC 60603-2

Type M for special contacts according to DIN 41626

Female connector

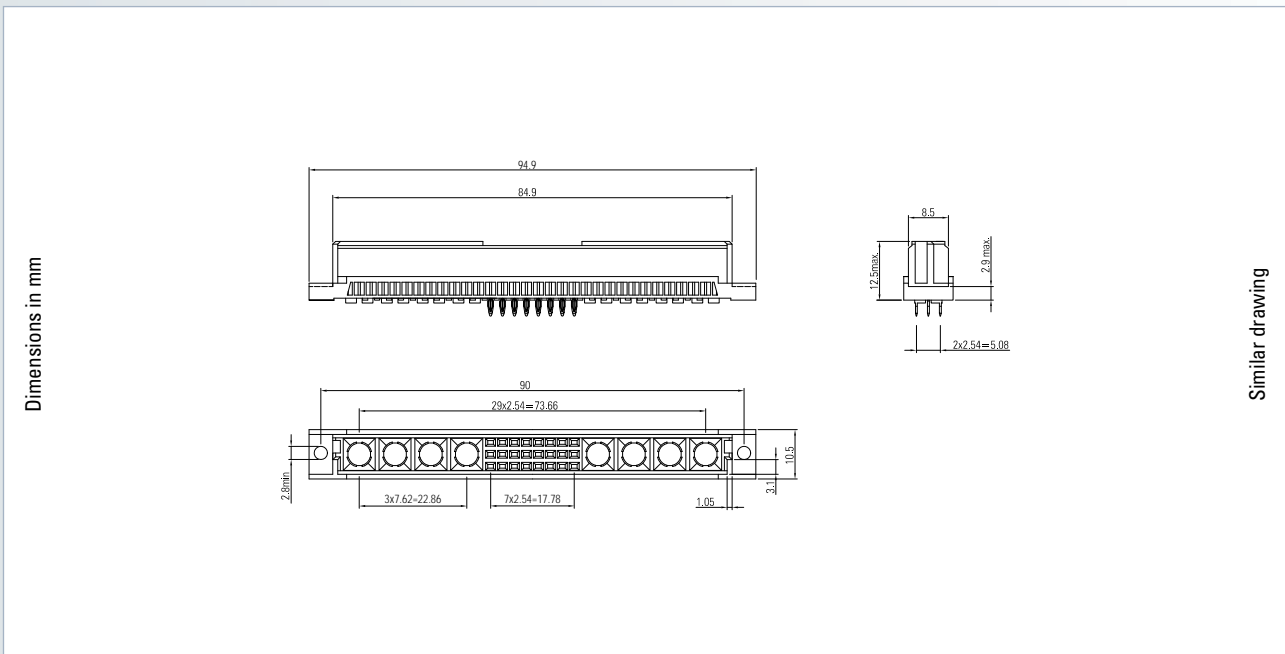

No. of contacts	Contact arrangement	Press-fit technology – Performance level II
		Termination length
		Part number
6/10		124-60112-00
24/8		124-60182-00
42/6		124-60162-00
60/4		124-60142-00
78/2		124-60122-00



Connectors according to DIN 41612 / IEC 60603-2
Type M for special contacts according to DIN 41626

Female connector

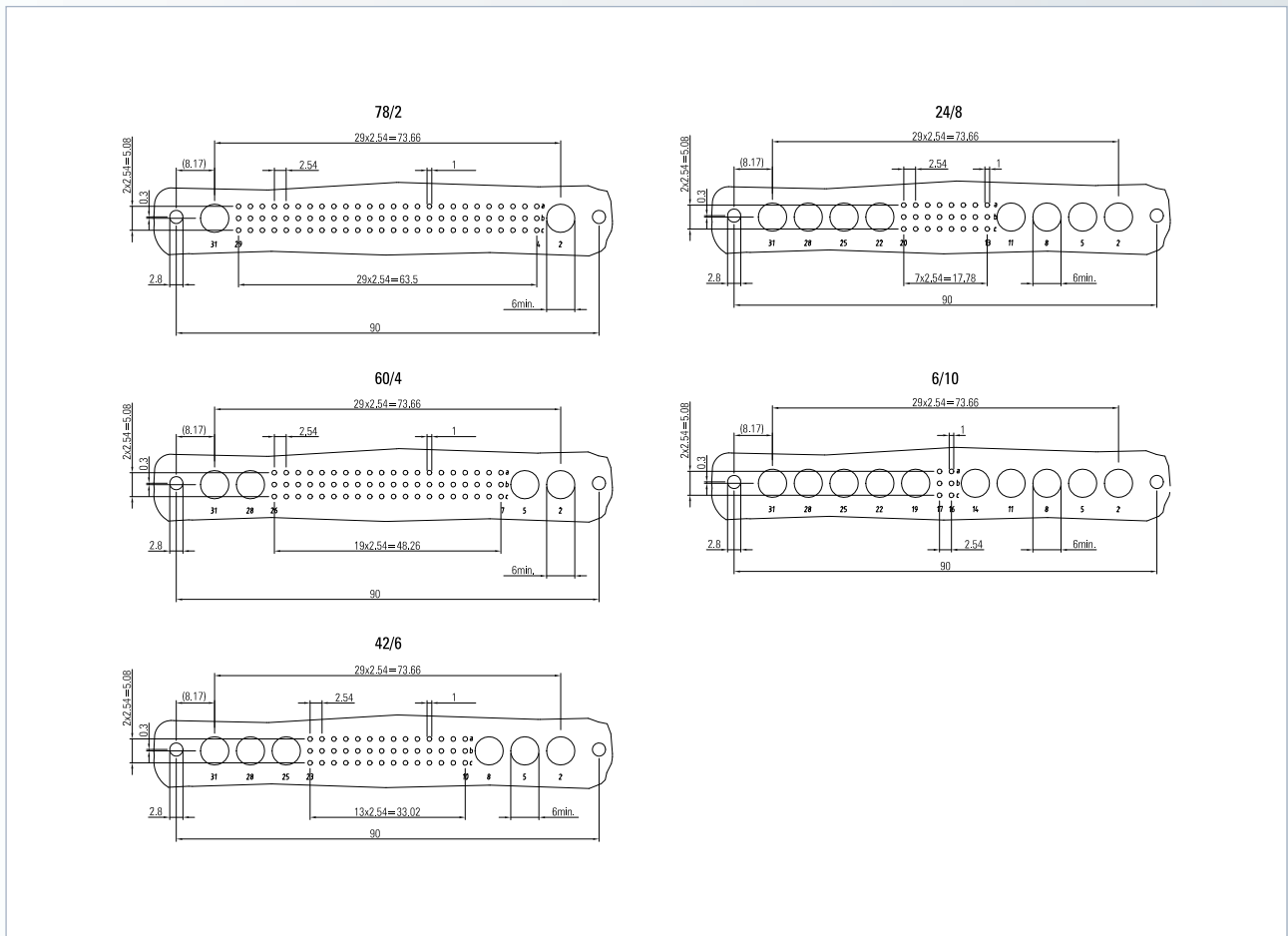

On request

- Performance levels I + III or customer-specific
- Special contact length
- Press-fit tool
- Support tool

Note

- Female connectors must be screwed or riveted onto the printed circuit board at the flange

Connectors according to DIN 41612 / IEC 60603-2

Type M for special contacts in press-fit technology

Female connector

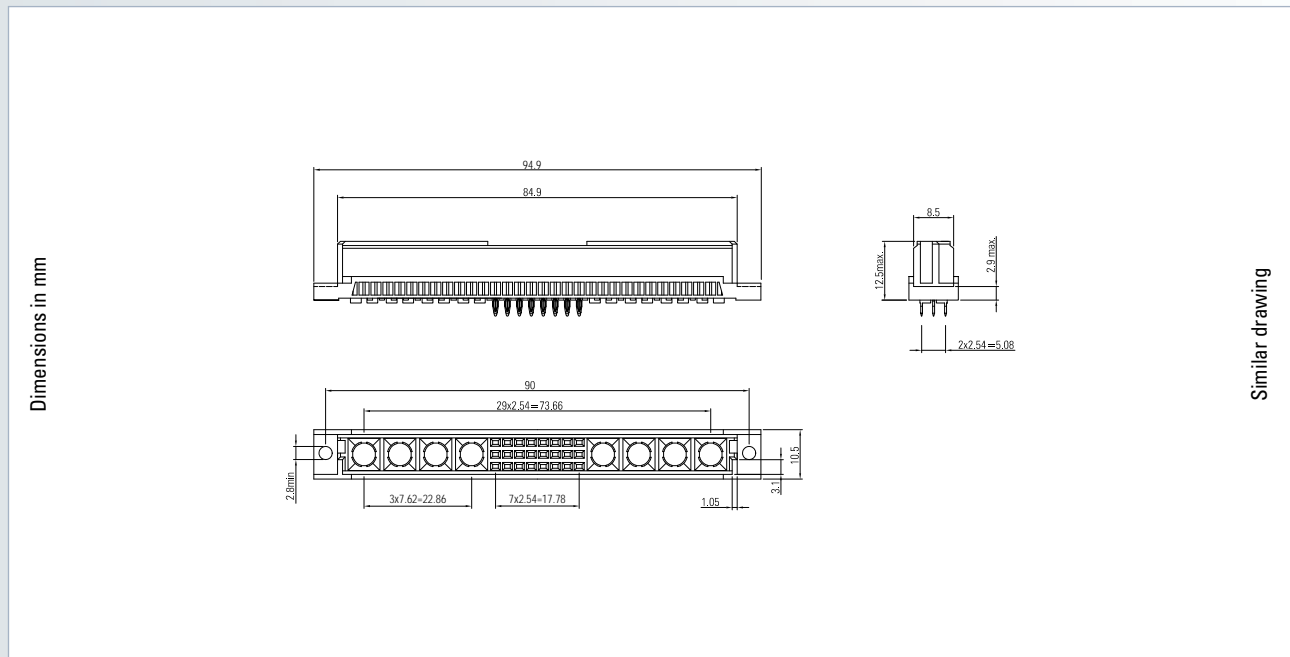

No. of contacts	Contact arrangement	Press-fit technology – Performance level II	
		Termination length	
		Special contact is not pre-loaded 4.6	Special contact is pre-loaded 4.6
Part number			
6/10		124-60012-00	124-60012-02
24/8		124-60082-00	124-60082-02
42/6		124-60062-00	124-60062-02
60/4		124-60042-00	124-60042-02
78/2		124-60022-00	124-60022-02



Connectors according to DIN 41612 / IEC 60603-2 Type M for special contacts in press-fit technology

Female connector

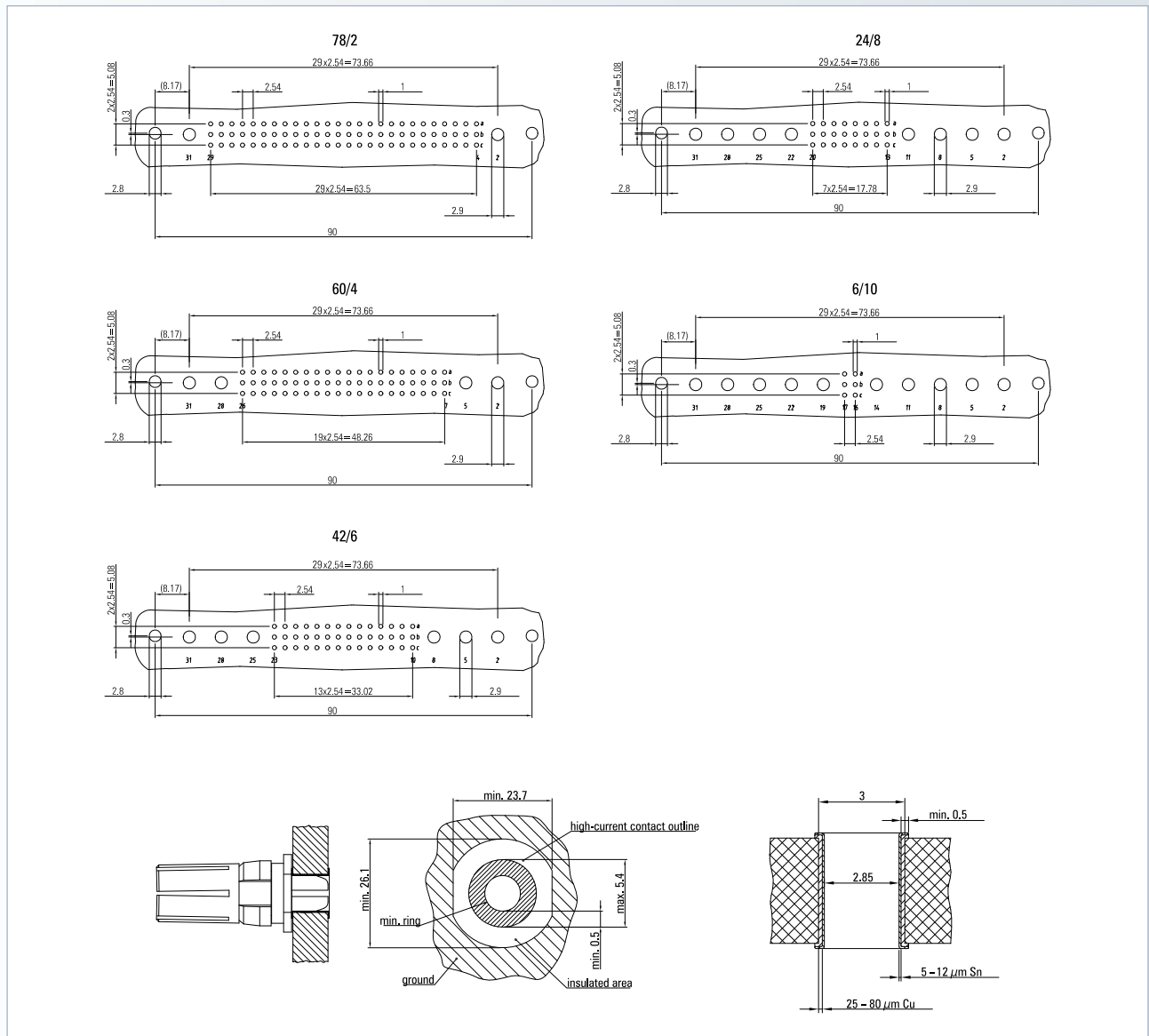

On request

- Performance levels I + III or customer-specific
- Special contact length
- Press-fit tool
- Support tool

Options

- Contact arrangement of the special contacts

Note

- Female connectors must be screwed or riveted onto the printed circuit at the flange

Connectors according to DIN 41612 / IEC 60603-2

Type M/2, M/3 for special contacts according to DIN 41626

Female connector

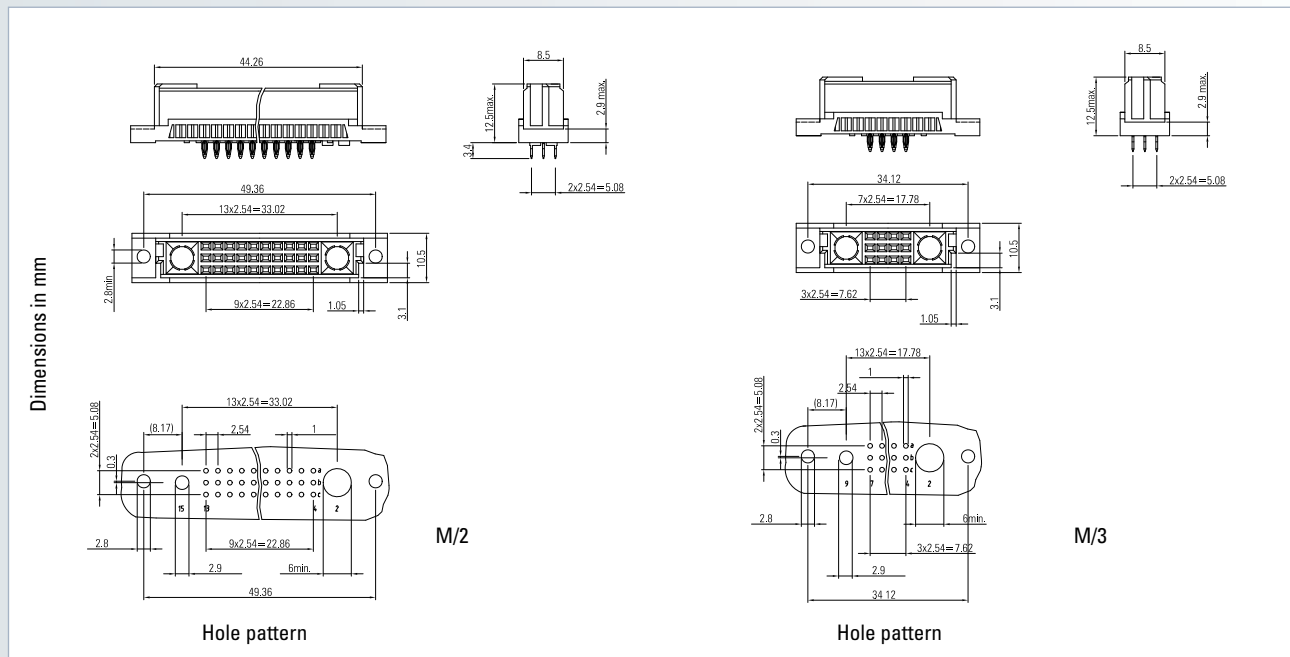

No. of contacts	Contact arrangement	Press-fit technology – Performance level II	
		Termination length	Part number
M/2 30/2			124-69122-00
M/3 12/2			124-68122-00

On request

- Performance levels I + III or customer-specific
- Special contact length
- Press-fit tool
- Support tool



Note

- Female connectors must be screwed or riveted onto the printed circuit at the flange

Connectors according to DIN 41612/IEC 60603-2
Type M/2, M/3 for special contacts in press-fit technology

Female connector

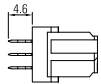
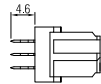

No. of contacts	Contact arrangement	Press-fit technology – Performance level II	
		Termination length	
		Special contact is not pre-loaded	Special contact is pre-loaded
			
		Part number	
M/2 30/2		124-69022-00	124-69022-02
M/3 12/2		124-68022-00	124-68022-02

<p>On request</p> <ul style="list-style-type: none"> – Performance levels I + III or customer-specific – Special contact length – Press-fit tool – Support tool 	<p>Options</p> <ul style="list-style-type: none"> – Contact arrangement of the special contacts 	<p>Note</p> <ul style="list-style-type: none"> – Female connectors must be screwed or riveted onto the printed circuit at the flange
--	---	--

Connectors according to DIN 41612 / IEC 60603-2

Type R

Male connector

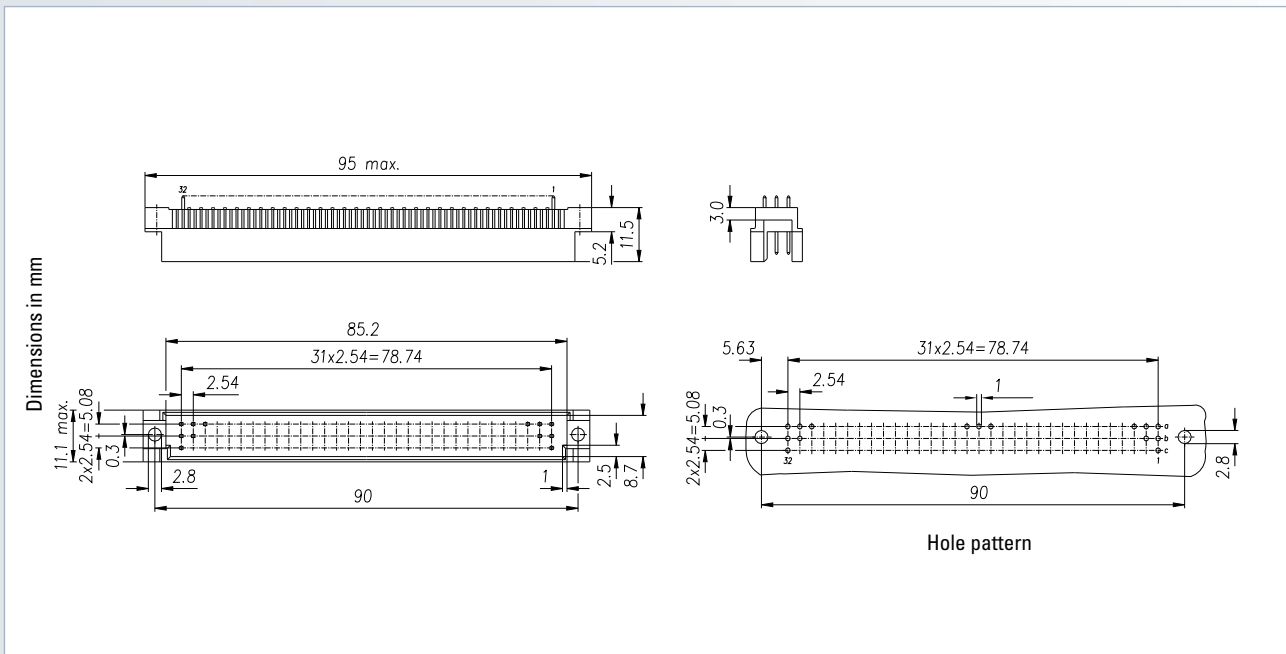

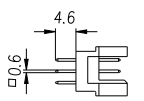
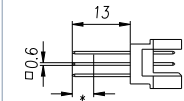
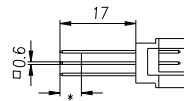
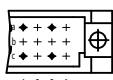
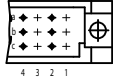
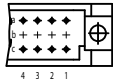
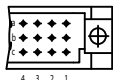
No. of contacts	Contact arrangement	Press-fit technology – Performance level II		
		Termination length		
				
Part number				
32		115-60014	115-65015	115-65016
48		115-60044	115-65045	115-65046
64		115-60054	115-65055	115-65056
96		115-60064	115-65065	115-65066

Accessories

- Press-fit tool (see page 206)
- Support tool (see page 207)
- Shroud (see page 158)

On request

- Performance levels I + III or customer-specific
- Special contact length
- Alternative surface Sn, e.g. for WireWrap

Options

- Contact arrangement (see page 162)

Note

- * Rear mating zone performance level II

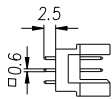
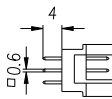
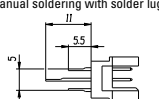
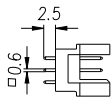
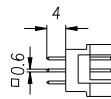
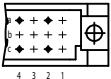
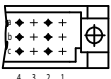
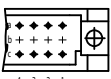
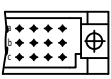

No. of contacts	Contact arrangement	Solder technology – Performance level II			THTR* – Performance level II	
		Termination length				
				Manual soldering with solder lug 		
Part number						
32		115-40015	115-40046	–	115-40015TH	115-40046TH
48		115-40026	115-40025	–	115-40026TH	115-40025TH
64		115-40035	115-40054	115-40036	115-40035TH	115-40054TH
96		115-40065	115-40074	115-40066	115-40065TH	115-40074TH

On request

- Performance levels I + III or customer-specific
- Special contact length
- Other termination lengths in THTR

Options

- Board lock (see page 159)
- Contact arrangement (see page 162)

Note

- * THTR (Through Hole Technology Reflow)

Connectors according to DIN 41612 / IEC 60603-2

Type R

Female connector

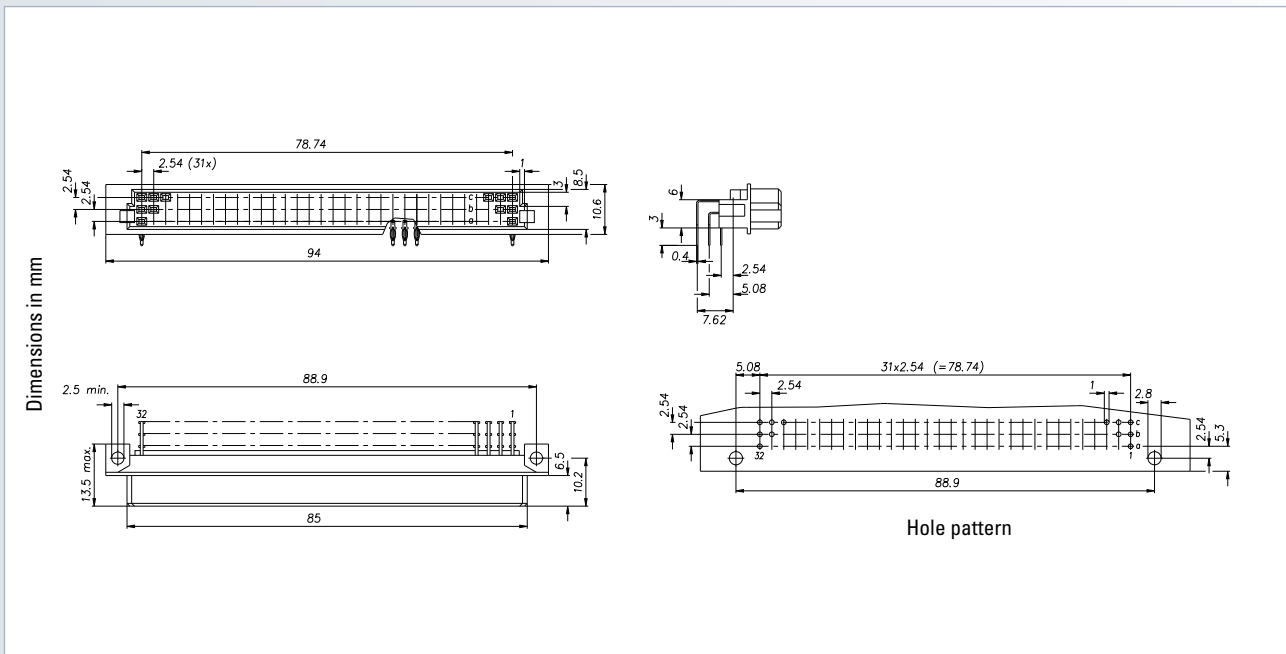

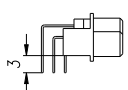
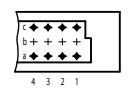
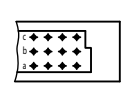
No. of contacts	Contact arrangement	Press-fit technology – Performance level II
		Termination length
		
		Part number
64		116-60054
96		116-60074

Accessories

- Press-fit tool (see page 210)
- Support tool (see page 211)

On request

- Performance levels I + III or customer-specific
- Special contact length

Options

- Without flange
- Contact arrangement (see page 162)

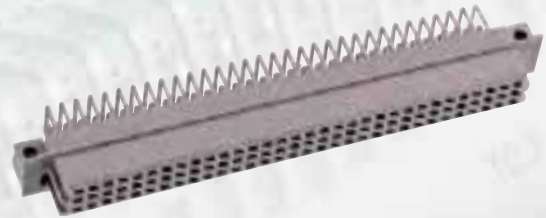

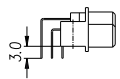
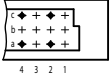
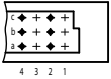
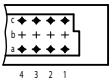
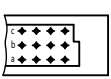
No. of contacts	Contact arrangement	Solder technology – Performance level II	
		Termination length	
			
		Part number	
32		116-40034	
48		116-40044	
64		116-40054	
96		116-40074	

On request

- Performance levels I + III or customer-specific
- Special contact length
- Also in THTR

Options

- Board lock (see page 159)
- Contact arrangement (see page 162)

Connectors according to DIN 41612 / IEC 60603-2

Type R/2

Male connector

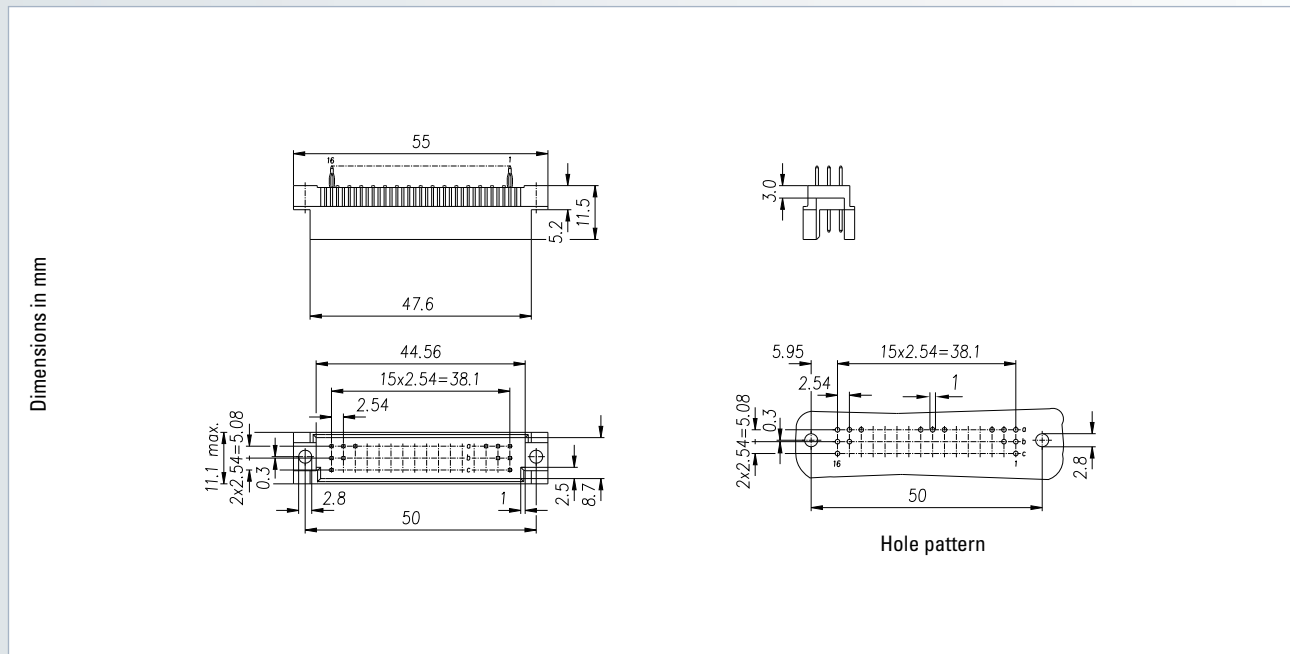

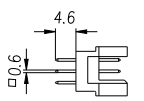
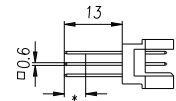
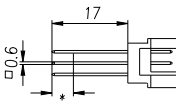
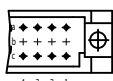
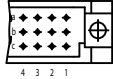
No. of contacts	Contact arrangement	Press-fit technology – Performance level II		
		Termination length		
				
Part number				
32		115-69054	115-79055	115-79056
48		115-69064	115-79065	115-79066

Accessories – Press-fit tool (see page 206) – Support tool (see page 207)	On request – Performance levels I + III or customer-specific – Special contact length – Alternative surface Sn, e.g. for WireWrap	Options – Contact arrangement (see page 162)
Note – * Rear mating zone performance level II		

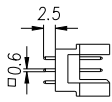
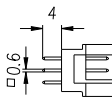
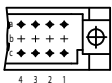
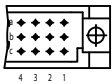

No. of contacts	Contact arrangement	Solder technology – Performance level II	
		Termination length	
			
Part number			
32		115-90014	115-90015
48		115-90064	115-90065

On request

- Performance levels I + III or customer-specific
- Special contact length
- Also in THTR

Options

- Board lock (see page 159)
- Contact arrangement (see page 162)

Connectors according to DIN 41612 / IEC 60603-2

Type R/2

Female connector

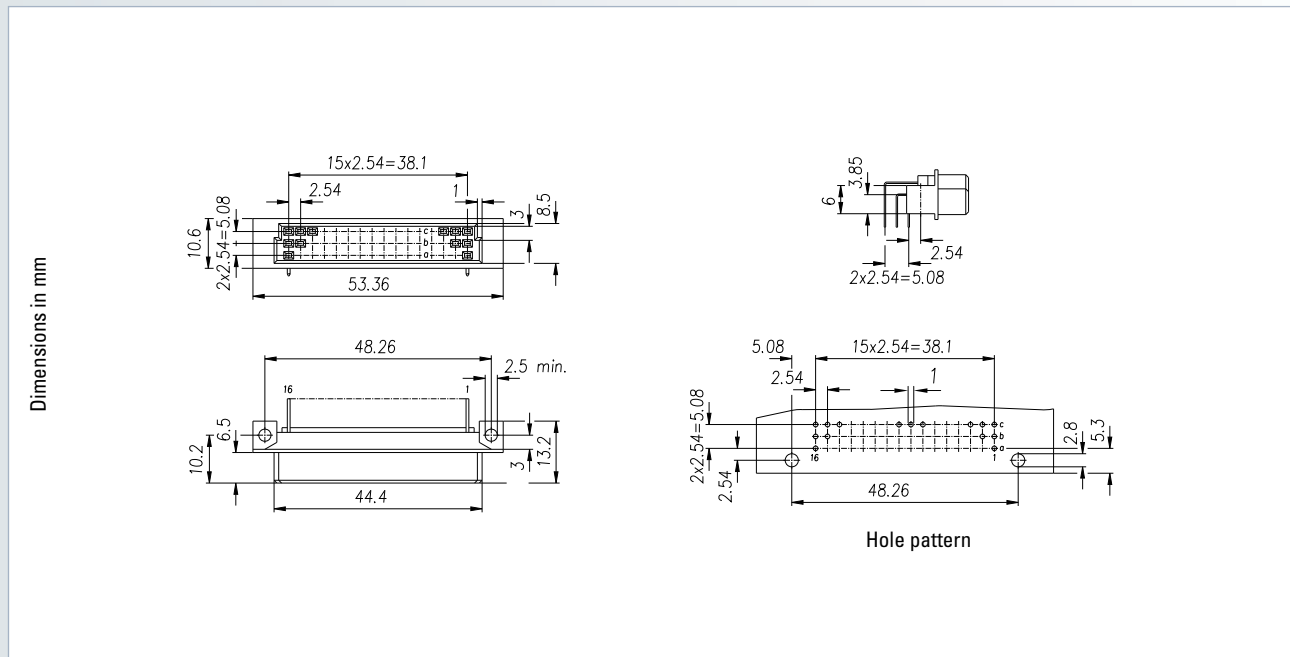

No. of contacts	Contact arrangement	Press-fit technology – Performance level II
		Termination length
		Part number
32		116-69054
48		116-69064

Accessories	On request	Options
<ul style="list-style-type: none"> – Press-fit tool (see page 210) – Support tool (see page 211) 	<ul style="list-style-type: none"> – Performance levels I + III or customer-specific – Special contact length 	<ul style="list-style-type: none"> – Without flange – Contact arrangement (see page 162)

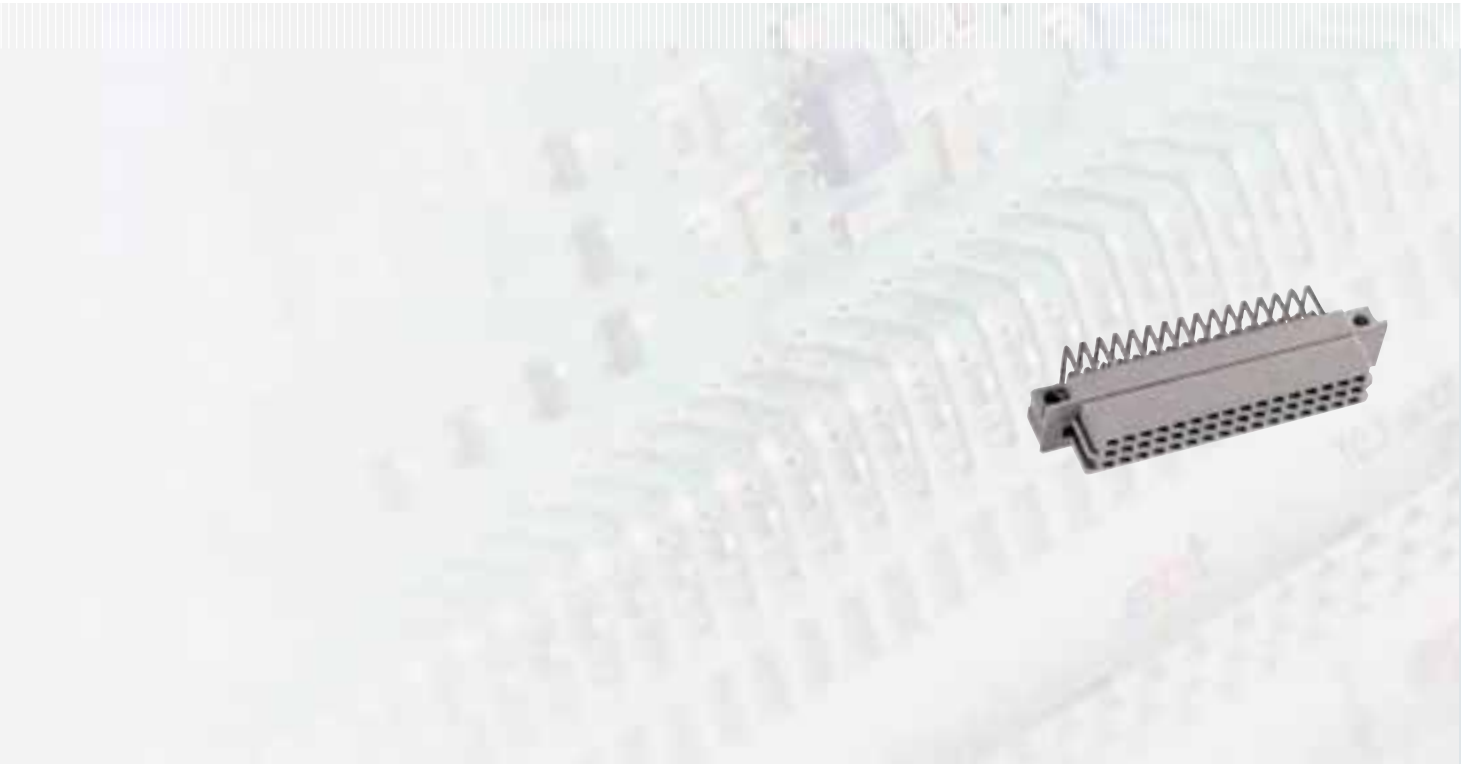

No. of contacts	Contact arrangement	Solder technology – Performance level II	
		Termination length	Part number
32			116-90054
48			116-90064

On request

- Performance levels I + III or customer-specific
- Special contact length
- Also in THTR

Options

- Board lock (see page 159)
- Contact arrangement (see page 162)

Connectors according to DIN 41612 / IEC 60603-2

Type R/3

Male connector

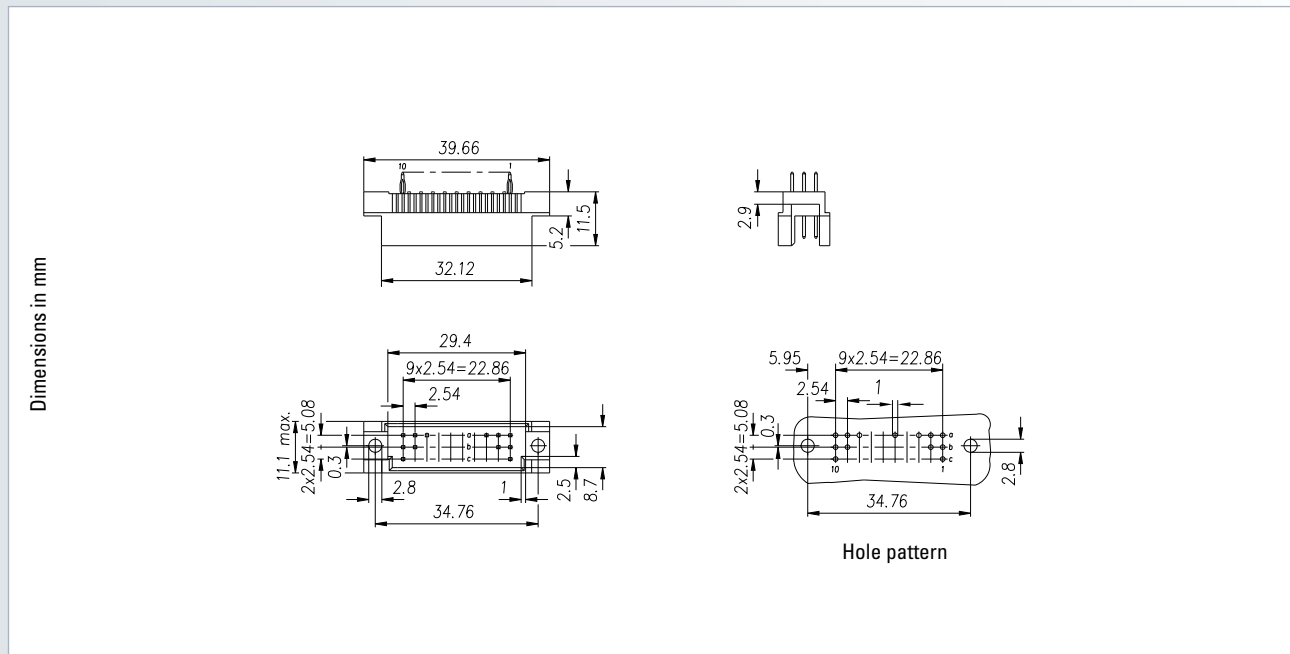

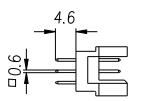
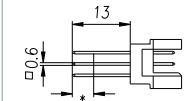
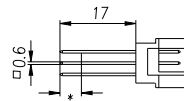
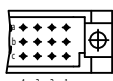
No. of contacts	Contact arrangement	Press-fit technology – Performance level II		
		Termination length		
				
30		115-68014	115-78015	115-78016

Accessories – Press-fit tool (see page 206) – Support tool (see page 207)	On request – Performance levels I + III or customer-specific – Special contact length – Alternative surface Sn, e.g. for WireWrap	Options – Contact arrangement (see page 162)
Note – * Rear mating zone performance level II		

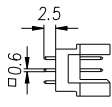
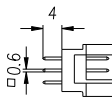
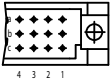

No. of contacts	Contact arrangement	Solder technology – Performance level II	
		Termination length	
			
Part number			
30		115-80064	115-80065

On request

- Performance levels I + III or customer-specific
- Special contact length
- Also in THTR

Options

- Board lock (see page 159)
- Contact arrangement (see page 162)

Connectors according to DIN 41612 / IEC 60603-2

Type R/3

Female connector

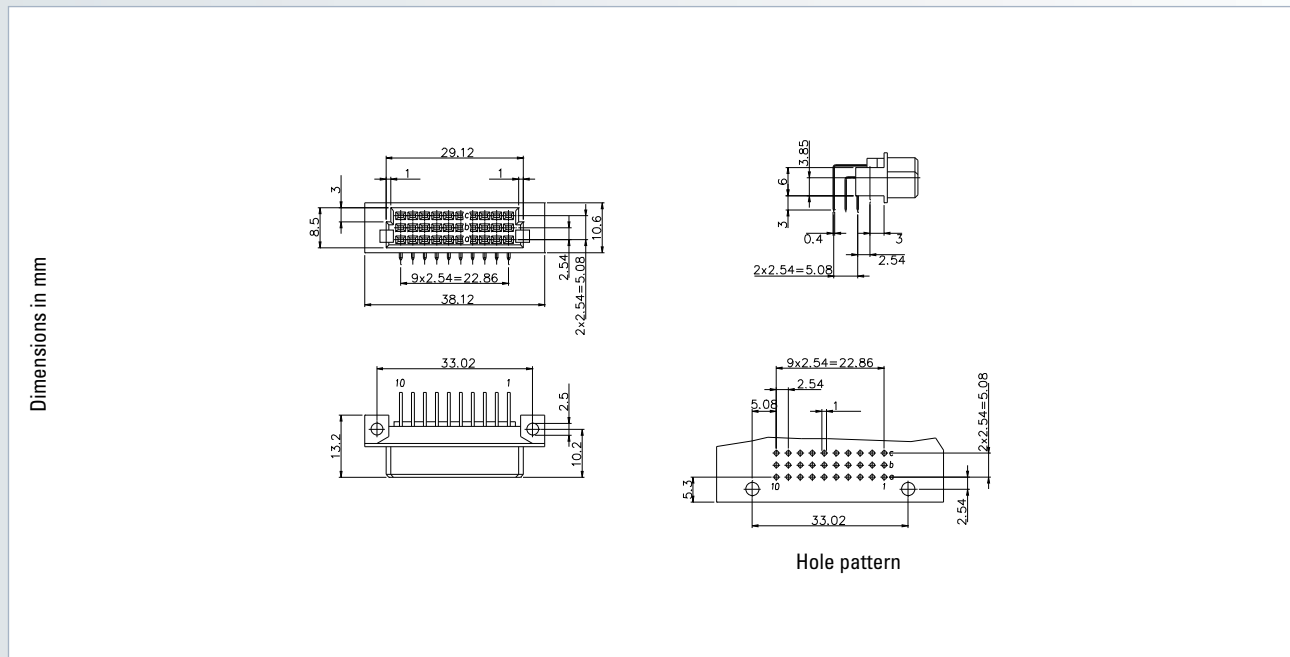

No. of contacts	Contact arrangement	Press-fit technology – Performance level II
		Termination length
		Part number
30		116-68064

Accessories	On request	Options
<ul style="list-style-type: none"> – Press-fit tool (see page 210) – Support tool (see page 211) 	<ul style="list-style-type: none"> – Performance levels I + III or customer-specific – Special contact length 	<ul style="list-style-type: none"> – Without flange – Contact arrangement (see page 162)



No. of contacts	Contact arrangement	Solder technology – Performance level II
		Termination length
		Part number
30		116-80064

On request

- Performance levels I + III or customer-specific
- Special contact length
- Also in THTR

Options



- Board lock (see page 159)
- Contact arrangement (see page 162)

Connectors according to DIN 41612 / IEC 60603-2

Type D

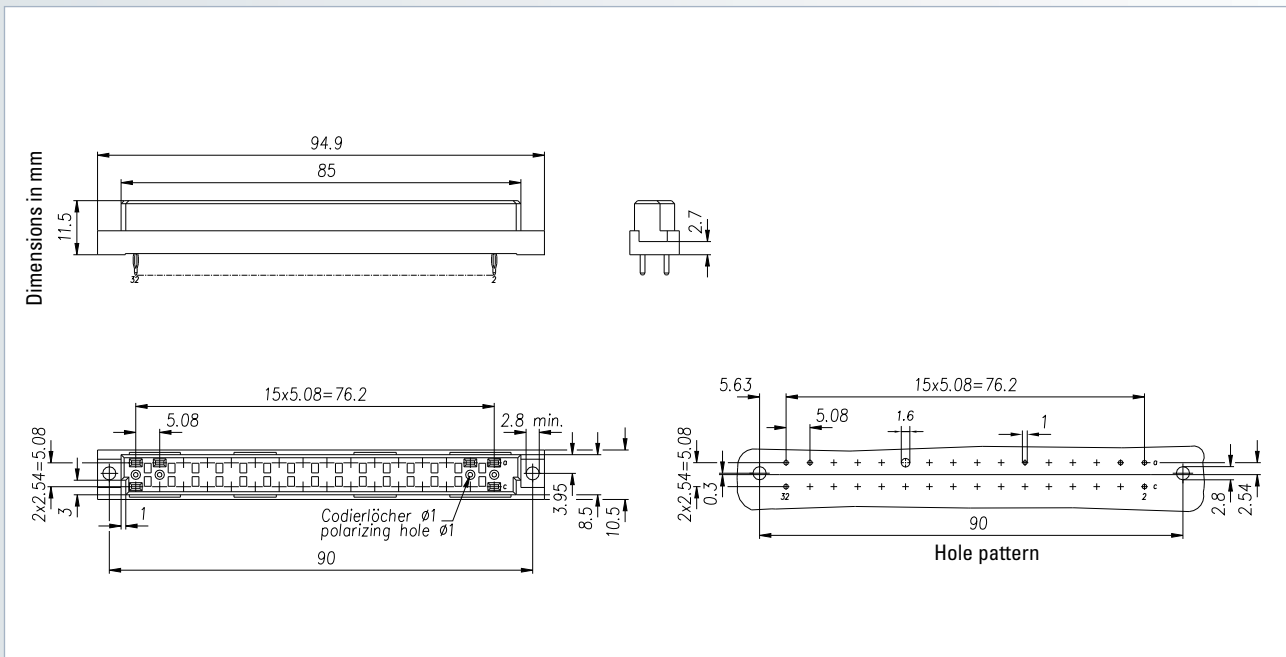
Female connector

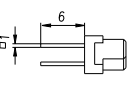
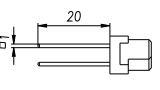

No. of contacts	Contact arrangement	Press-fit technology – Performance level II		
		Termination length		
				
Part number				
32		106-60084	106-60064	106-60065

Accessories

- Press-fit tool (see page 208)
- Support tool (see page 209)
- Coding accessories (see page 160)



On request

- Performance levels I + III or customer-specific
- Special contact length

Options

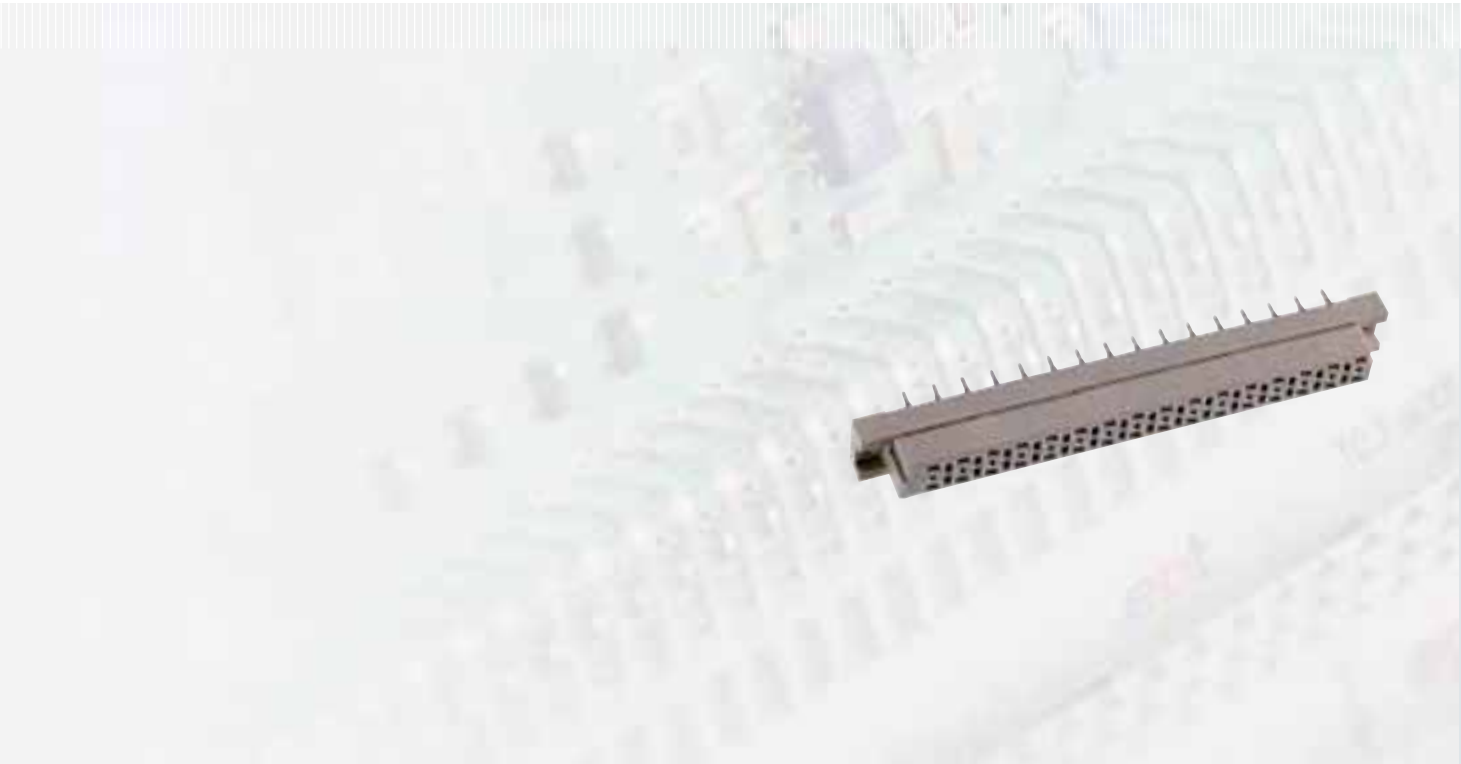
- Without flange
- Contact arrangement (see page 162)

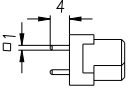
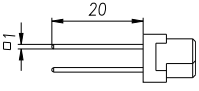
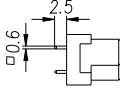
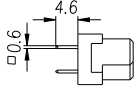

No. of contacts	Contact arrangement	Solder technology – Performance level II				
		Termination length				
						
Part number						
32		106-40064	106-40065	106-40084	106-40075	106-40066

<p>Accessories</p> <ul style="list-style-type: none"> – Coding accessories (see page 160) 	<p>On request</p> <ul style="list-style-type: none"> – Performance levels I + III or customer-specific – Special contact length – Also in THTR 	<p>Options</p> <ul style="list-style-type: none"> – Board lock (see page 159) – Contact arrangement (see page 162)
---	--	---

Connectors according to DIN 41612 / IEC 60603-2

Type D

Male connector

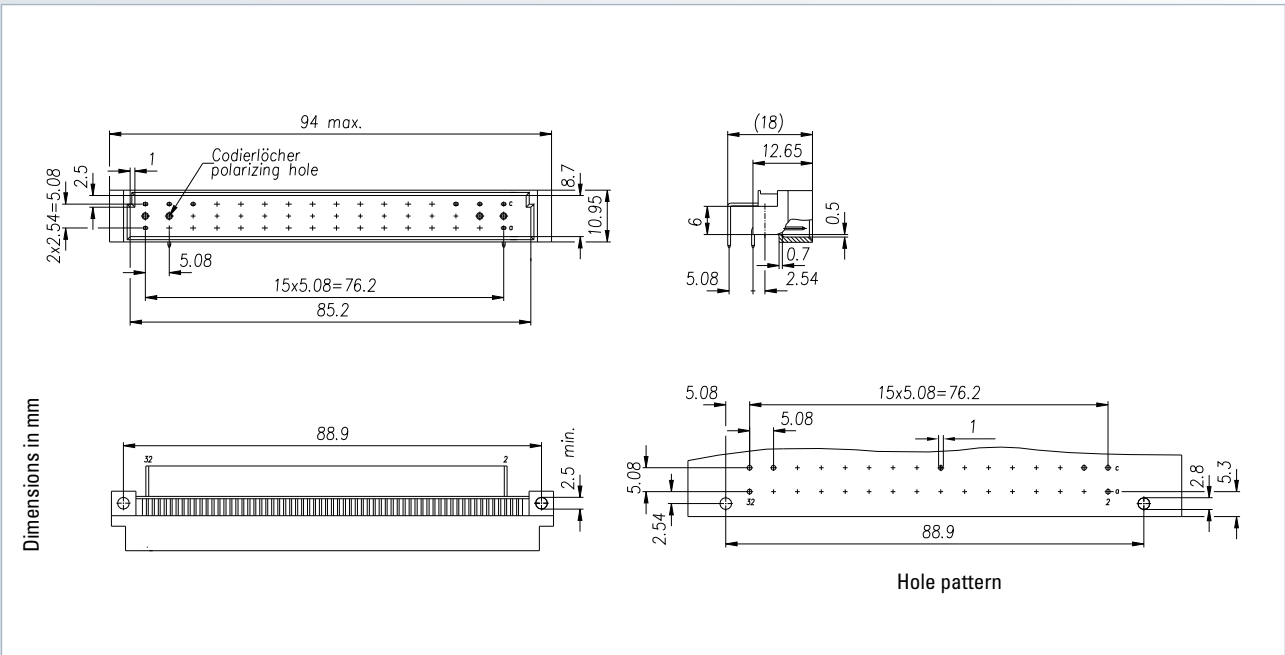

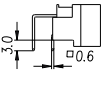
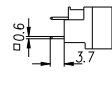
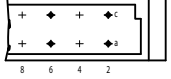
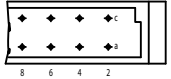
No. of contacts	Contact arrangement	Solder technology – Performance level II	
		Termination length	
			
Part number			
16		105-40014	105-40016
32		105-40064	105-40066



Accessories	On request	Options
<ul style="list-style-type: none"> - Coding accessories (see page 160) 	<ul style="list-style-type: none"> - Performance levels I + III or customer-specific - Special contact length - Also in THTR 	<ul style="list-style-type: none"> - Board lock (see page 159) - Contact arrangement (see page 162)

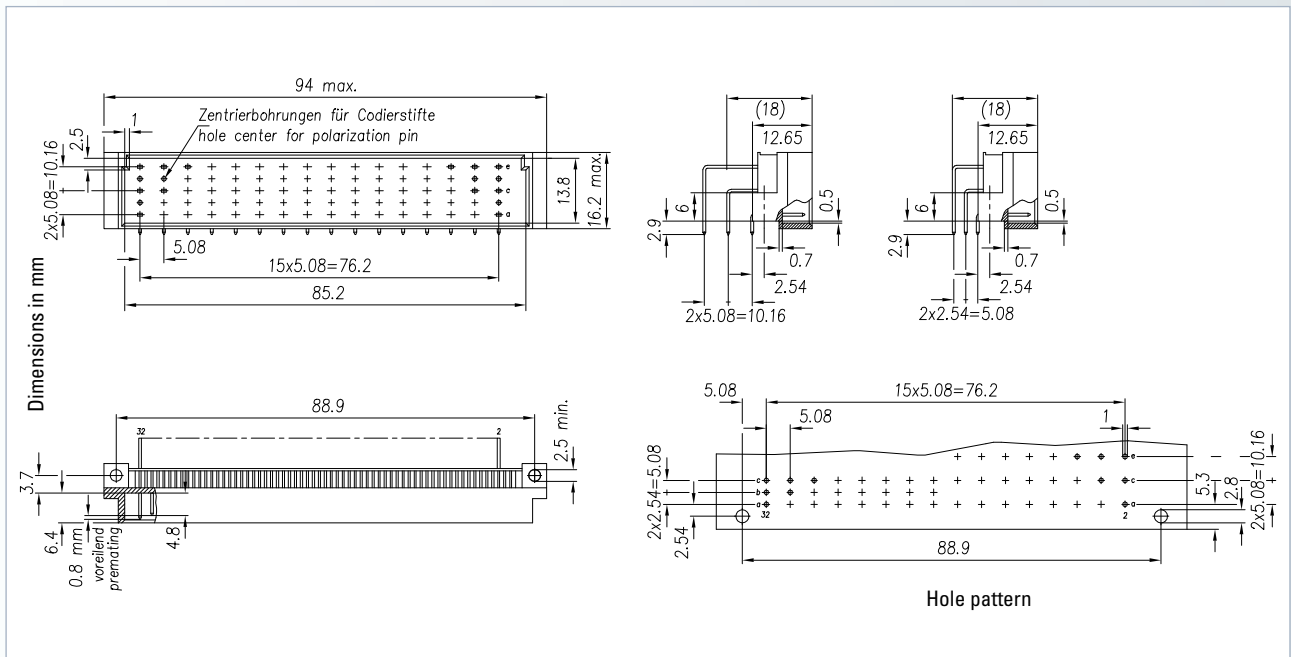

No. of contacts	Contact arrangement	Solder technology – Performance level II		
		Termination length		
Part number				
32		107-40024	107-40025	107-40026
32		107-40014	107-40015	107-40016
48		107-40064	107-40065	107-40066



Accessories – Coding accessories (see page 160)	On request – Performance levels I + III or customer-specific – Special contact length – Also in THTR	Options – Board lock (see page 159) – Contact arrangement (see page 162)
---	--	---

Connectors according to DIN 41612 / IEC 60603-2

Type E



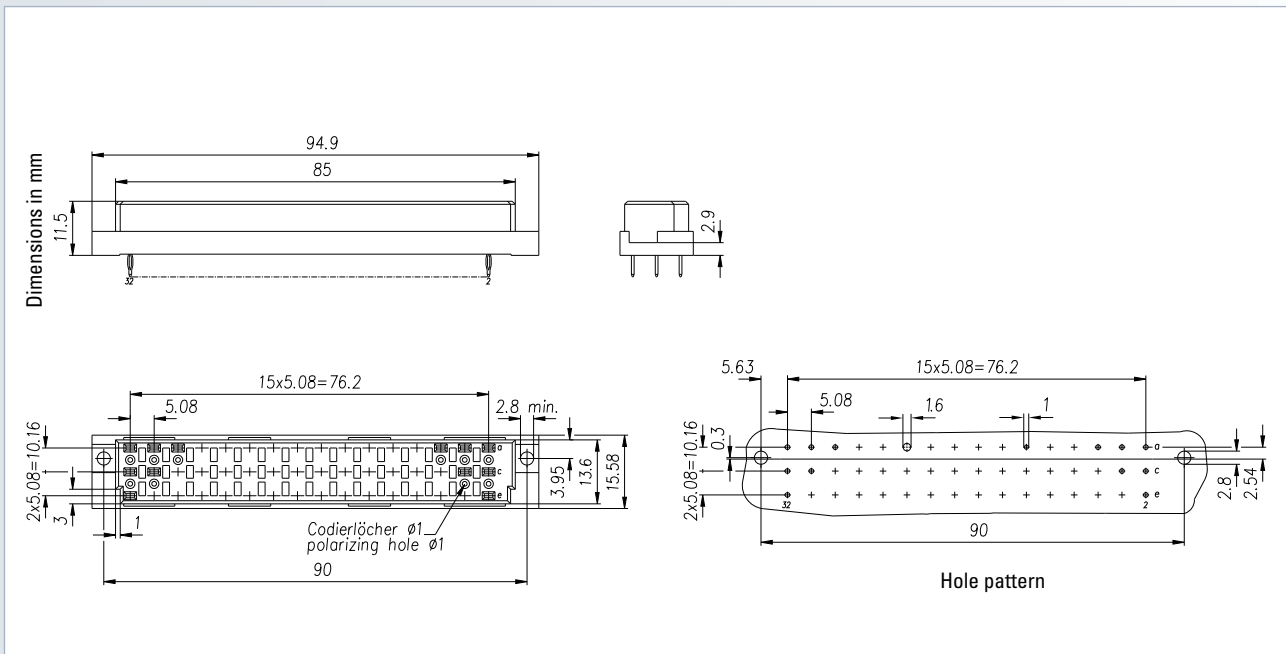

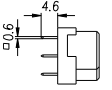
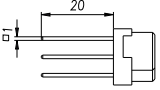
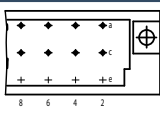
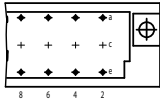
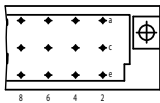
Female connector

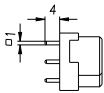
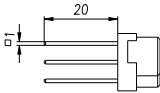

No. of contacts	Contact arrangement	Press-fit technology – Performance level II	
		Termination length	
			
Part number			
32		108-60054	108-60015
32		108-60044	108-60025
48		108-60084	108-60065

Accessories	On request	Options
<ul style="list-style-type: none"> – Press-fit tool (see page 208) – Support tool (see page 209) – Coding accessories (see page 160) 	<ul style="list-style-type: none"> – Performance levels I + III or customer-specific – Special contact length 	<ul style="list-style-type: none"> – Without flange – Contact arrangement (see page 162)

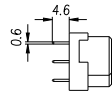

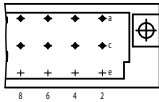
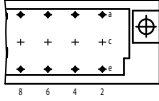
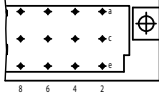
No. of contacts	Contact arrangement	Solder technology – Performance level II				
		Termination length				
						
Part number						
32		108-40014	108-40015	–	108-40044	108-40046
32		108-40024	108-40025	–	108-40034	108-40036
48		108-40064	108-40065	108-40084	108-40074	108-40076

Accessories – Coding accessories (see page 160)	On request – Performance levels I + III or customer-specific – Special contact length – Also in THTR	Options – Board lock (see page 159) – Contact arrangement (see page 162)
---	--	---

Connectors according to DIN 41612 / IEC 60603-2

Type F

Male connector

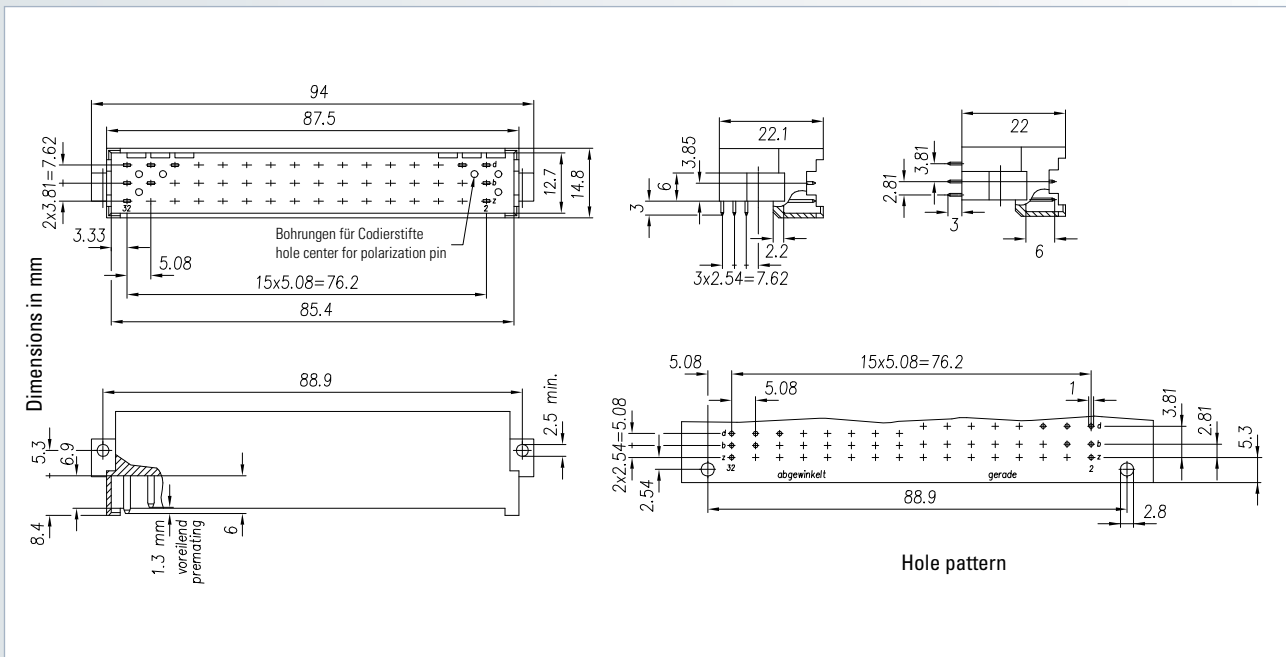

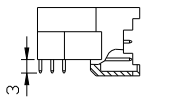
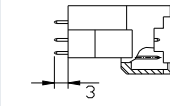
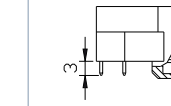
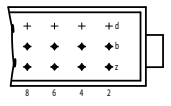
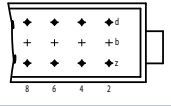
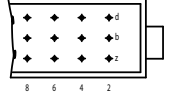
No. of contacts	Contact arrangement	Solder technology – Performance level II		
		Termination length		
				
Part number				
32		–	109-40025	109-40024
32		109-40014	109-40015	–
48		109-40064	109-40065	–

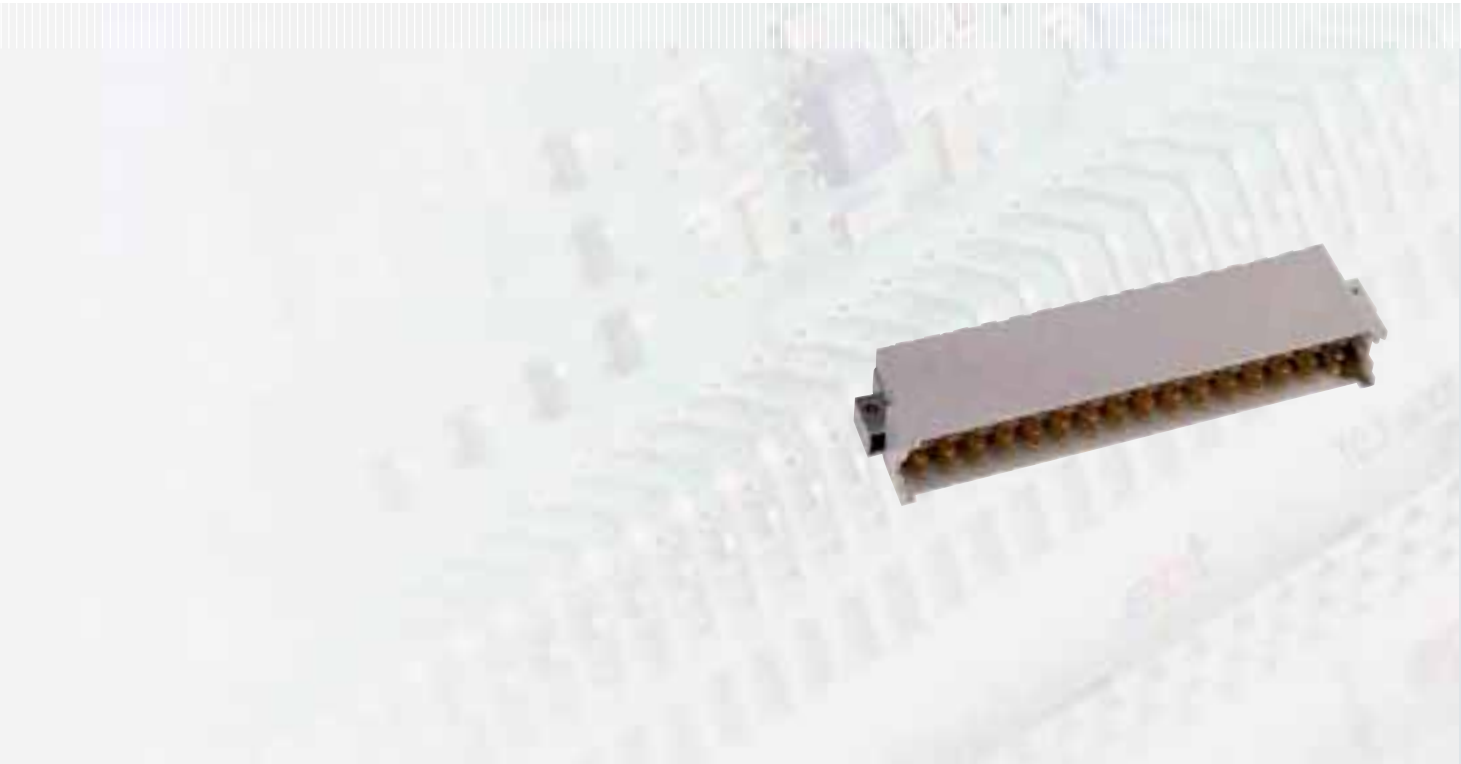

Accessories

– Coding accessories (see page 160)

On request

– Performance levels I + III or customer-specific
– Special contact length
– Also in THTR

Options

– Board lock (see page 159)
– Contact arrangement (see page 162)

Connectors according to DIN 41612 / IEC 60603-2

Type F

Female connector

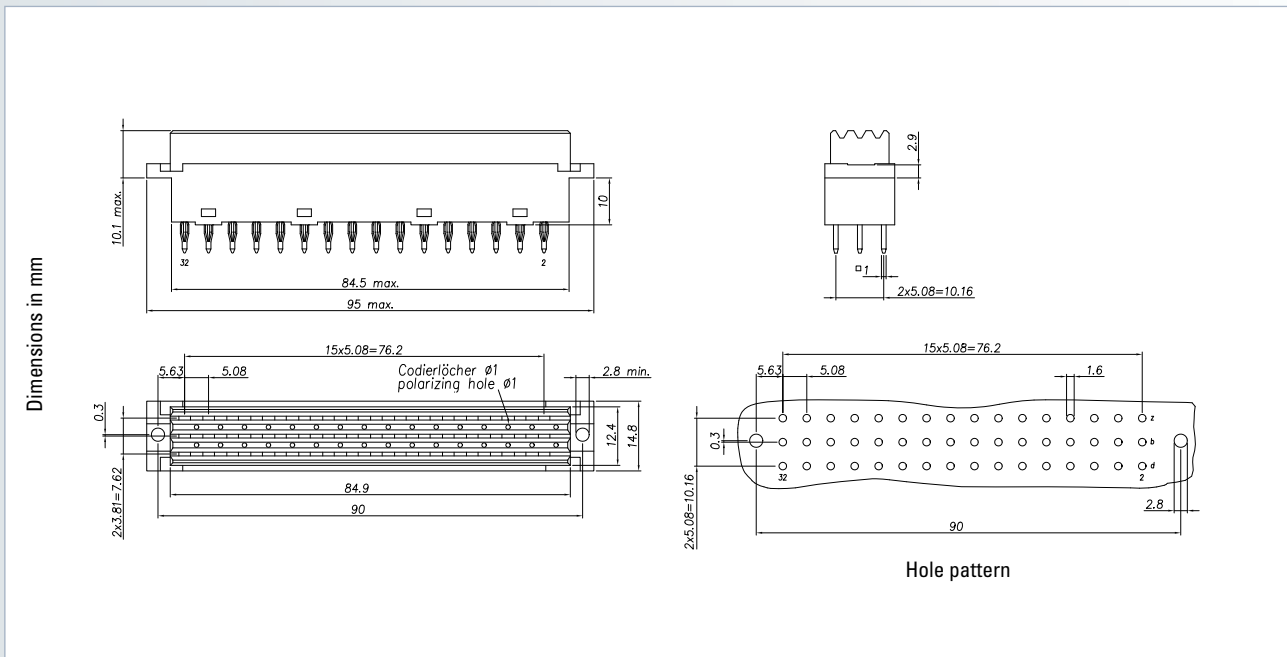

No. of contacts	Contact arrangement	Press-fit technology – Performance level II	
		Termination length	
Part number			
32		110-60025	110-60024
32		110-60015	110-60014
48		110-60065	110-60064

Accessories	On request	Options
<ul style="list-style-type: none"> – Press-fit tool (see page 208) – Support tool (see page 209) – Coding accessories (see page 160) 	<ul style="list-style-type: none"> – Performance level I + III or customer-specific – Special contact length 	<ul style="list-style-type: none"> – Special contact arrangement (see page 162)

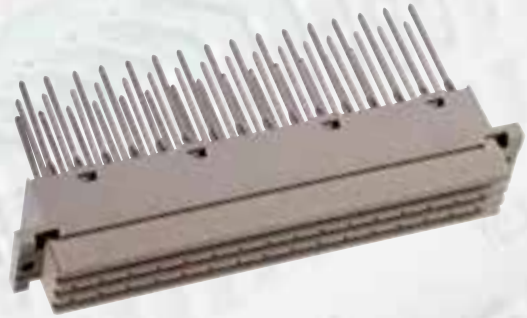

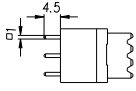
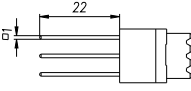
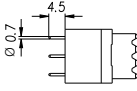
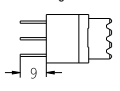
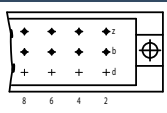
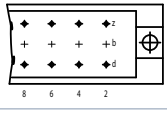
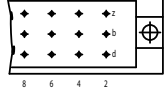
No. of contacts	Contact arrangement	Solder technology – Performance level II			
		Termination length			
					Manual soldering with solder lug 
Part number					
32		110-40025	110-40024	110-40005	110-40026
32		110-40015	110-40014	110-40004	110-40016
48		110-40065	110-40064	110-40084	110-40066

Accessories – Coding accessories (see page 160)	On request – Performance level I + III or customer-specific – Special contact length – Also in THTR	Options – Special contact arrangement (see page 162)
---	---	--

Connectors according to DIN 41612 / IEC 60603-2

Type F low profile

Female connector

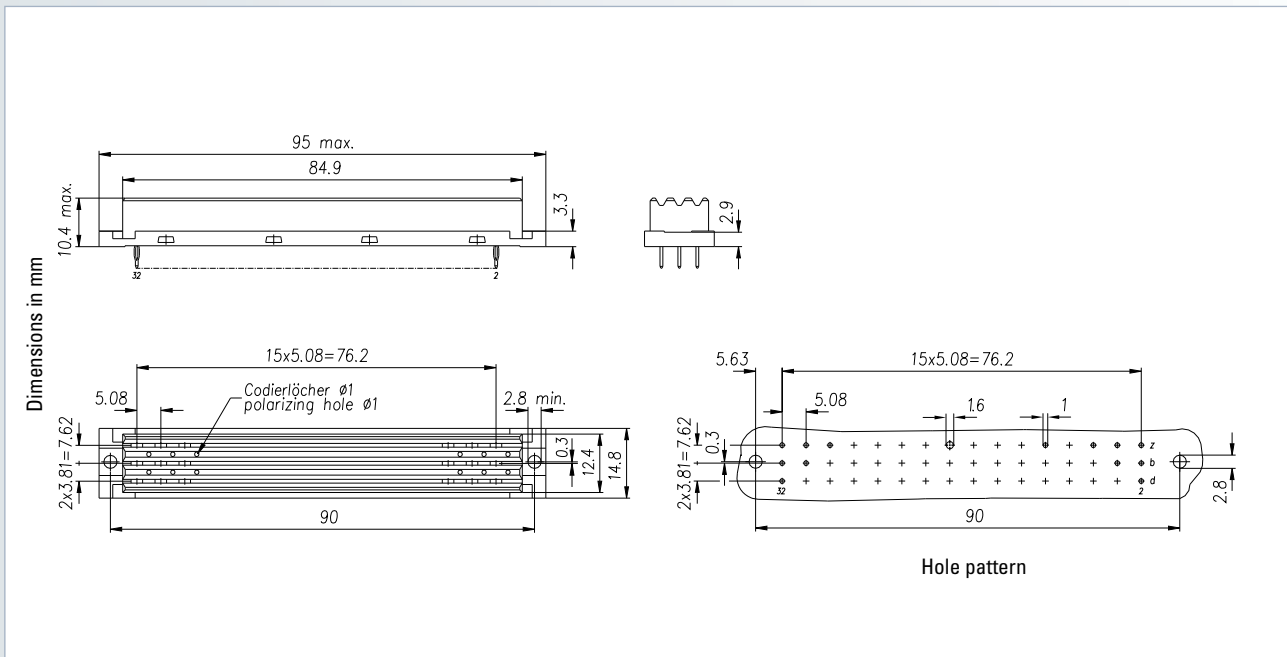

No. of contacts	Contact arrangement	Press-fit technology – Performance level II	
		Termination length	
		Part number	
32		110-61005	110-66025
32		110-61004	110-66015
48		110-61084	110-66065

Accessories

- Press-fit tool (see page 208)
- Support tool (see page 209)
- Coding accessories (see page 160)

On request

- Performance level I + III or customer-specific
- Special contact length

Options

- Without flange
- Special contact arrangement (see page 162)

Note

- * Rear mating zone performance level II

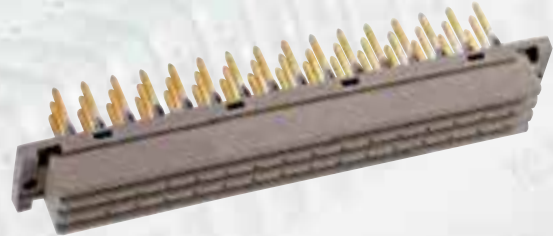

No. of contacts	Contact arrangement	Solder technology – Performance level II
		Termination length
		Part number
32		110-40505
32		110-40504
48		110-40584

Accessories – Coding accessories (see page 160)	On request – Performance level I + III or customer-specific – Special contact length – Also in THTR	Options – Board lock (see page 159) – Special contact arrangement (see page 162)
---	---	---

Connectors according to DIN 41612 / IEC 60603-2

Type G

Male connector

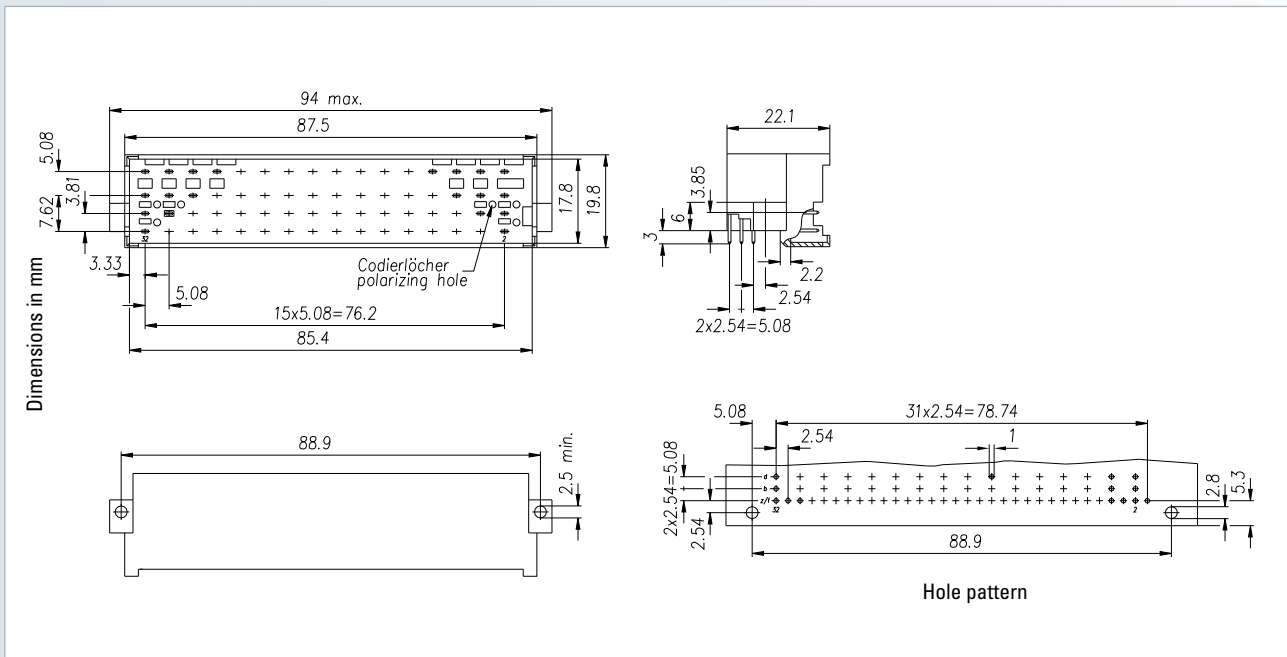

No. of contacts	Pre-mating contact at position	Contact arrangement	Solder technology – Performance level II	
			Termination length	
			Part number	
64	Without		111-40064	
64	Z 2		111-40164	
64	Z 2 and Z 32		111-40264	



Accessories – Coding accessories (see page 160)	On request – Performance level I + III or customer-specific – Also in THTR	Options – Board lock (see page 159) – Special contact arrangement (see page 162)
---	---	---

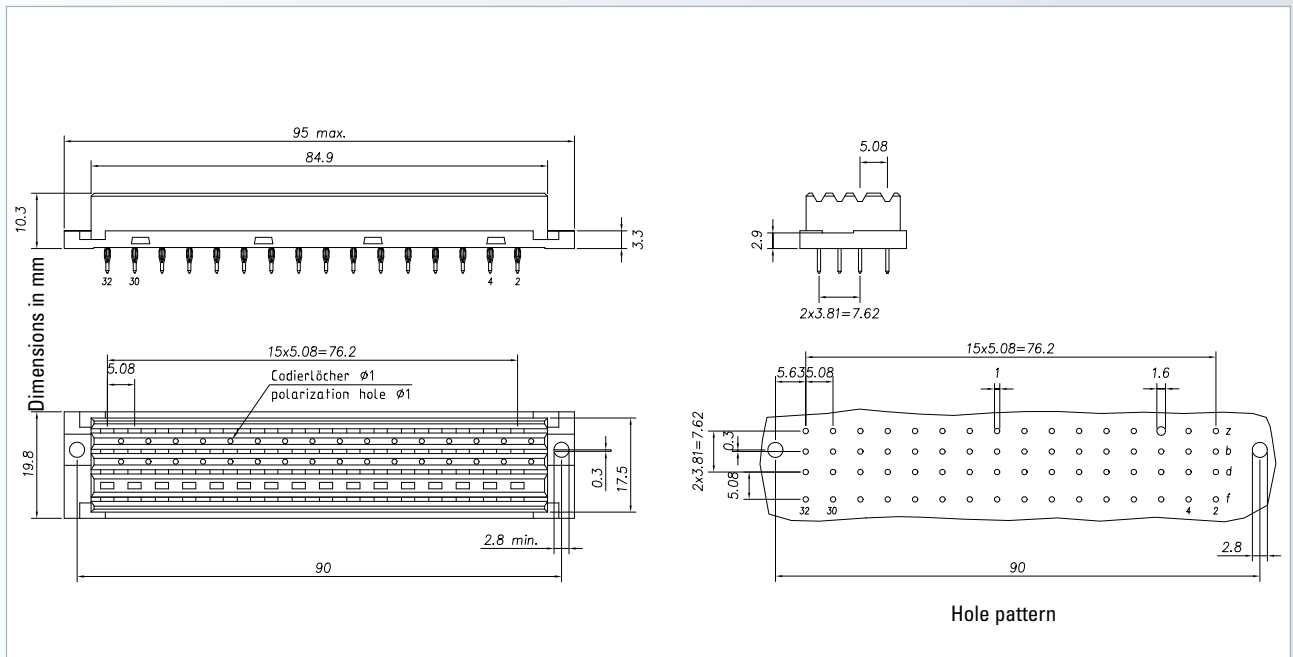

No. of contacts	Contact arrangement	Press-fit technology – Performance level II	
		Termination length	
		Part number	
64		112-61084	112-66065



Accessories	On request	Options
<ul style="list-style-type: none"> – Press-fit tool (see page 208) – Support tool (see page 209) – Coding accessories (see page 160) 	<ul style="list-style-type: none"> – Performance level I + III or customer-specific – Special contact length 	<ul style="list-style-type: none"> – Without flange – Special contact arrangement (see page 162)

Connectors according to DIN 41612 / IEC 60603-2

Type G

Female connector

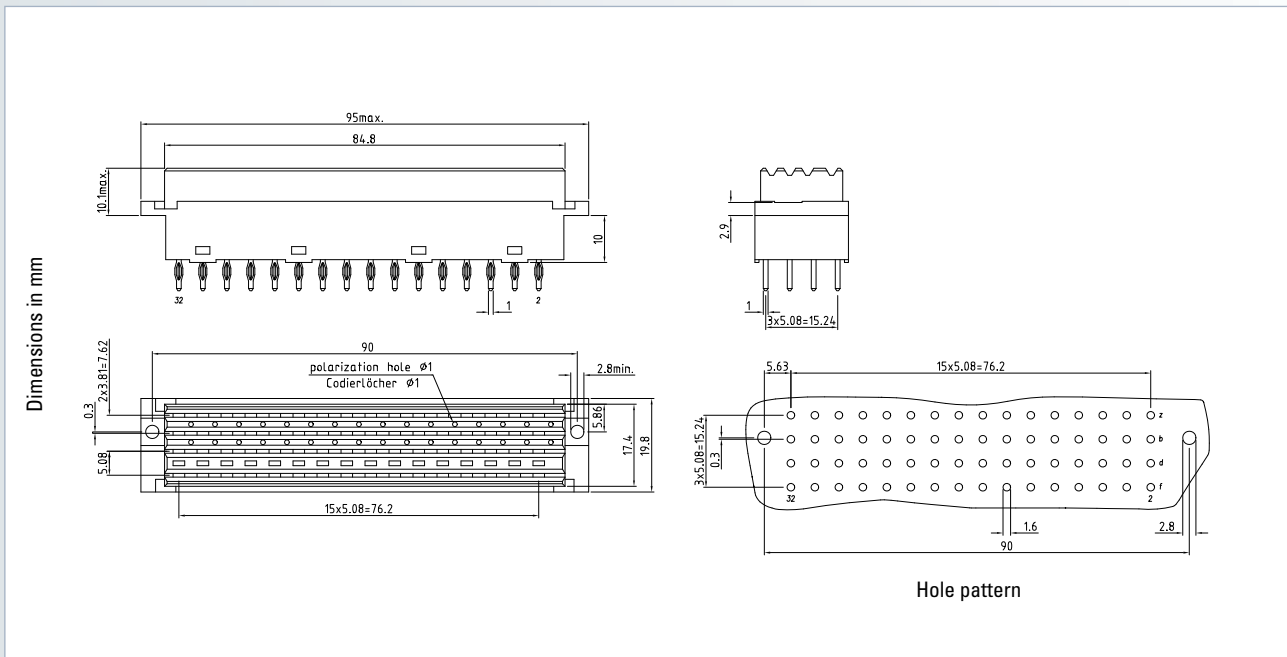

No. of contacts	Contact arrangement	Press-fit technology – Performance level II	
		Termination length	
		Part number	
64		112-60064	112-60065

Accessories <ul style="list-style-type: none"> – Press-fit tool (see page 208) – Support tool (see page 209) – Coding accessories (see page 160) 	On request <ul style="list-style-type: none"> – Performance level I + III or customer-specific – Special contact length 	Options <ul style="list-style-type: none"> – Without flange – Special contact arrangement (see page 162)
--	--	---

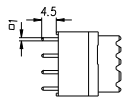
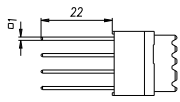
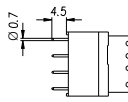
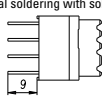
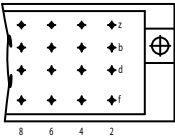

No. of contacts	Contact arrangement	Solder technology – Performance level II			
		Termination length			
					Manual soldering with solder lug 
Part number					
64		112-40064	112-40065	112-40084	112-40095

Accessories

– Coding accessories (see page 160)

On request

– Performance level I + III or customer-specific
– Special contact length
– Also in THTR

Options

– Board lock (see page 159)
– Special contact arrangement (see page 162)

Connectors according to DIN 41612 / IEC 60603-2

Type H11

Male connector

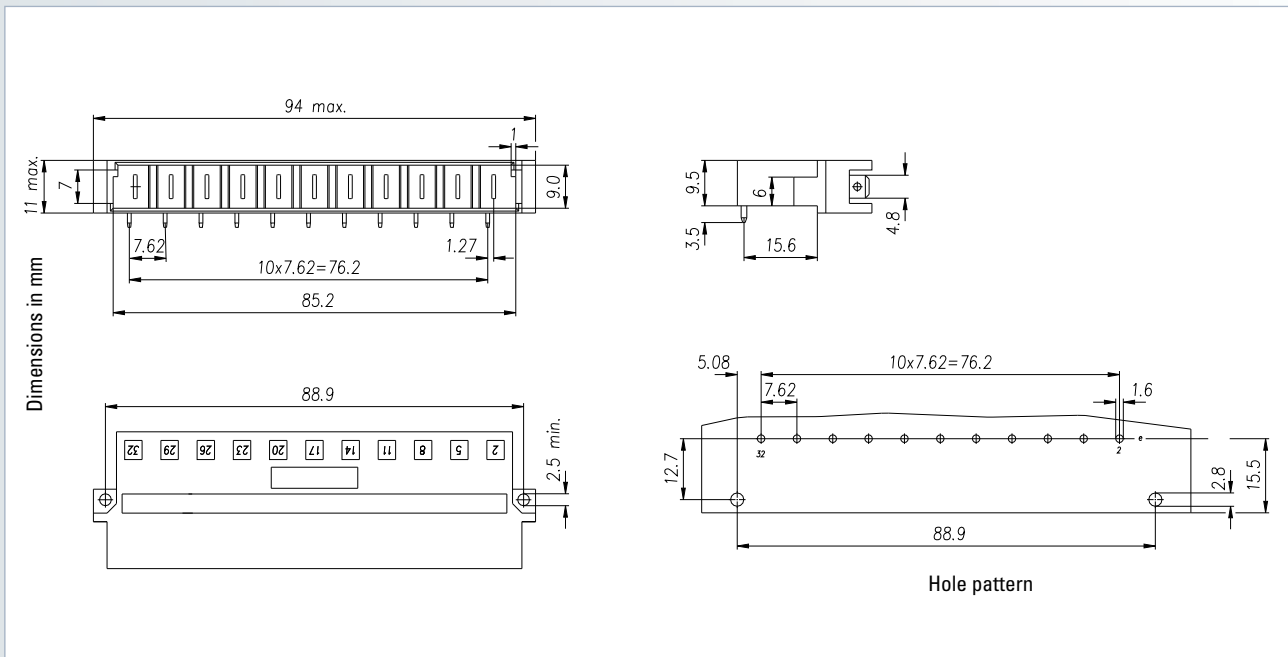

No. of contacts	Pre-mating contact at position	Contact arrangement	Solder technology – Performance level II	
			Termination length	Part number
11	Without			113-40010
10+1	32			113-40015
9+2	2; 32			113-40020



Accessories

– Coding accessories (see page 160)

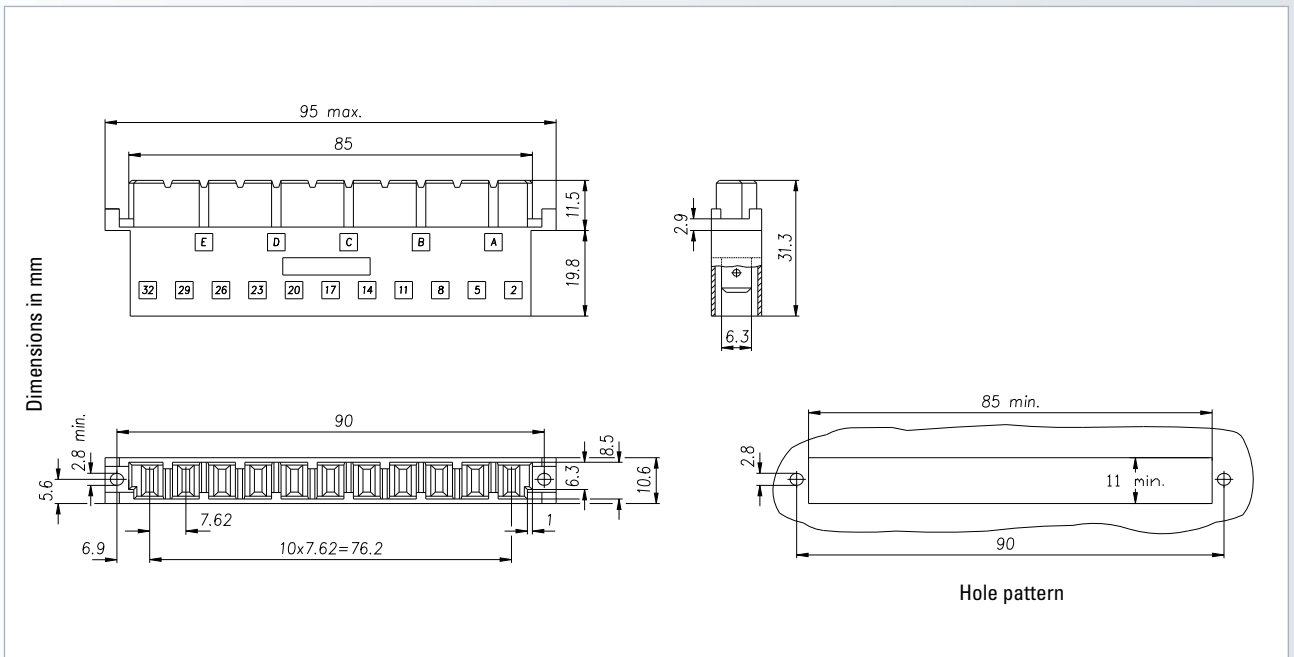

No. of contacts	Contact arrangement	Faston – Performance level II	
		Termination length	Part number
11			114-40040



Accessories

– Coding accessories (see page 160)

Connectors according to DIN 41612 / IEC 60603-2

Type H11 low profile

Female connector

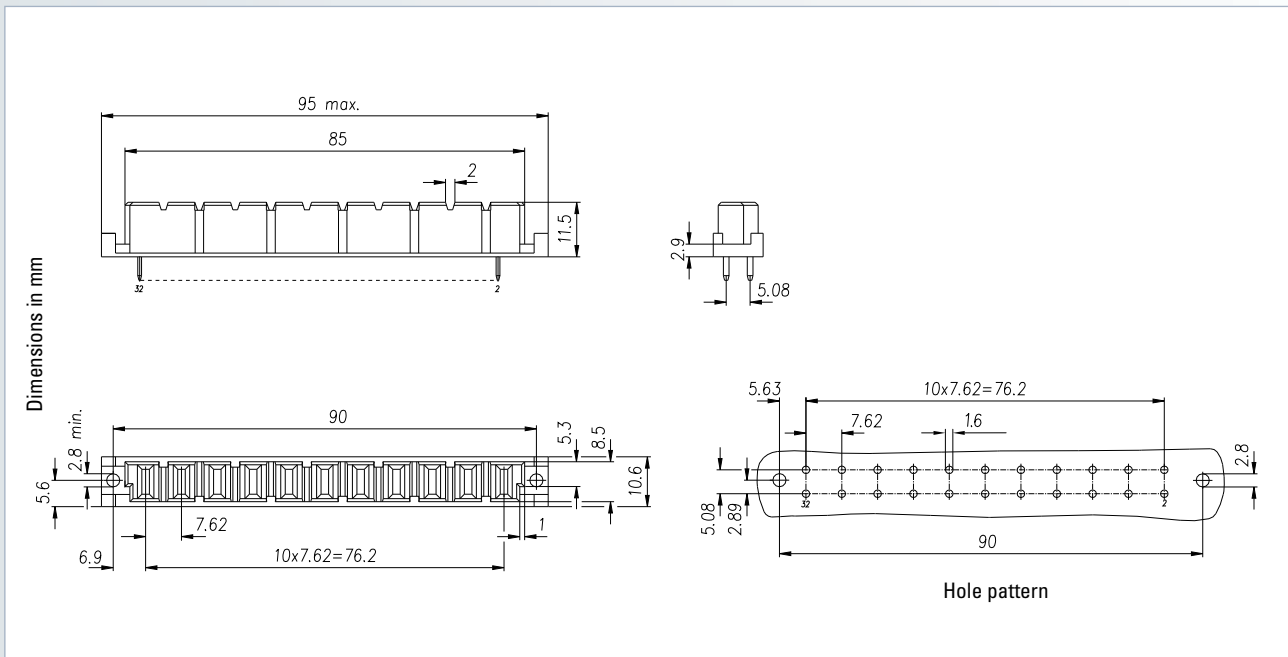

No. of contacts	Contact arrangement	Solder technology – Performance level II	
		Termination length	
		Part number	
11		114-40050	



Accessories

– Coding accessories (see page 160)

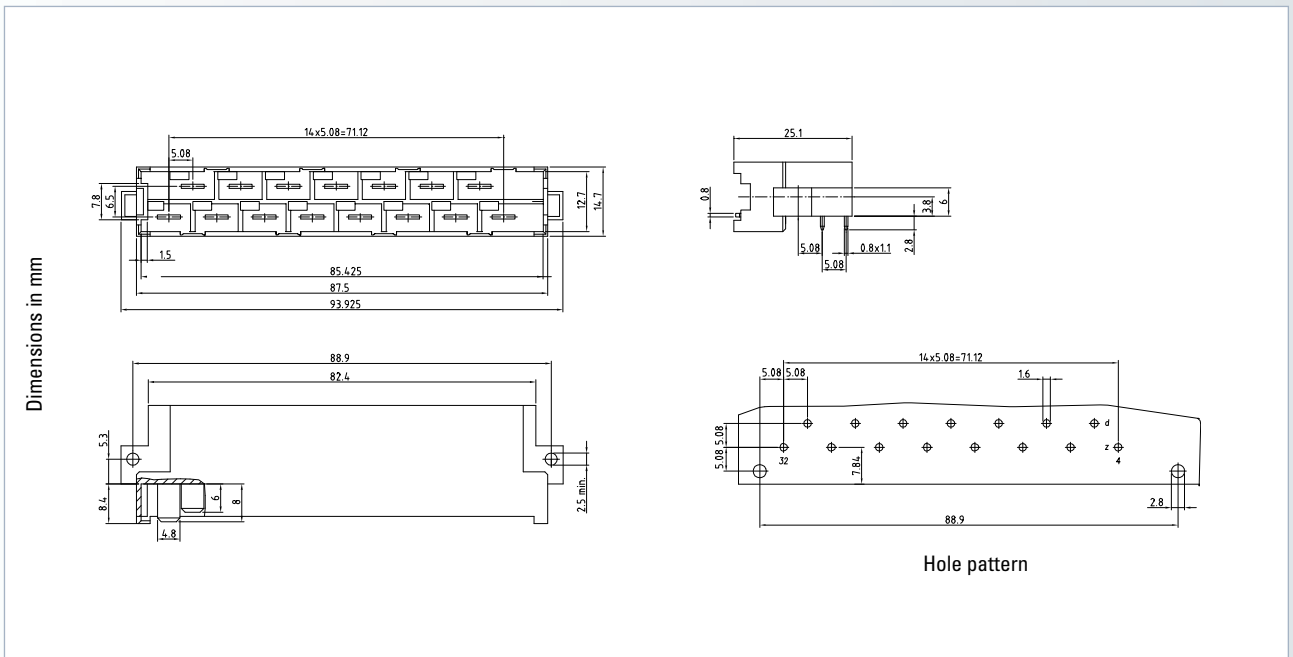

No. of contacts	Pre-mating contact at position	Contact arrangement	Solder technology – Performance level II	
			Termination length	Part number
15	Z 32			113-40060
15	Z 4 and Z 32			113-40160



Options

- Board lock (see page 159)

Connectors according to DIN 41612 / IEC 60603-2

Type H15

Female connector

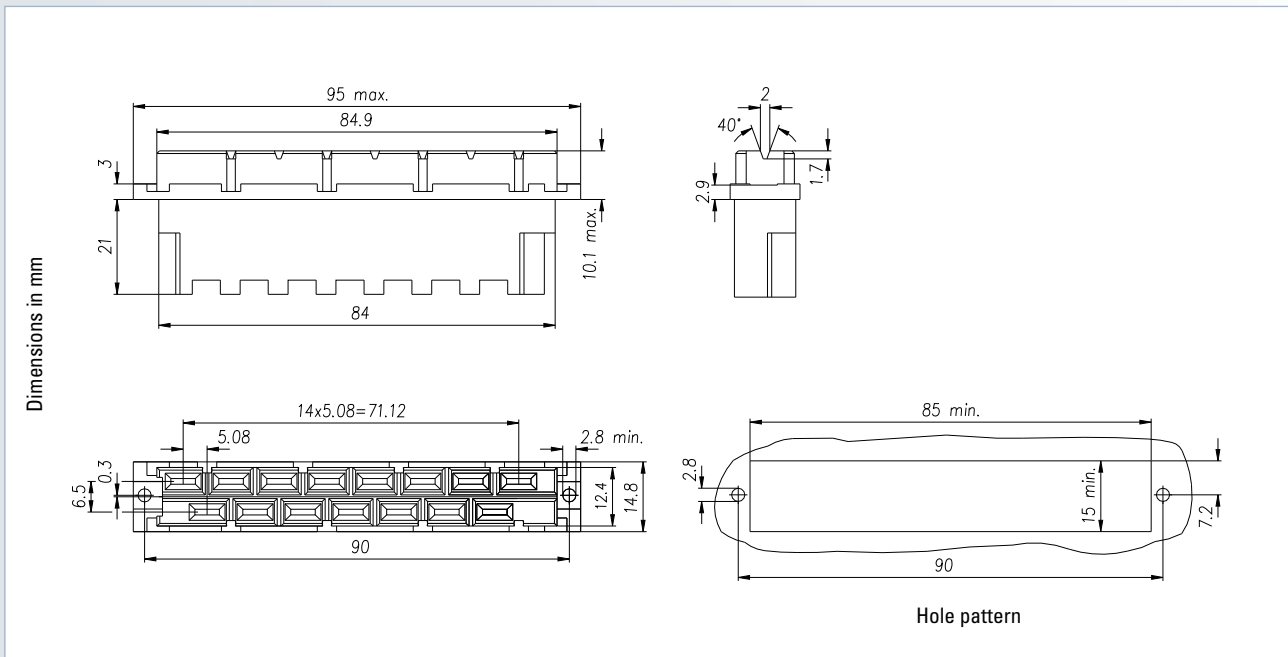

No. of contacts	Contact arrangement	Faston – Performance level II	
		Termination length	Part number
15			114-40060



Options

– Board lock (see page 159)

Accessories

– Coding accessories (see page 160)

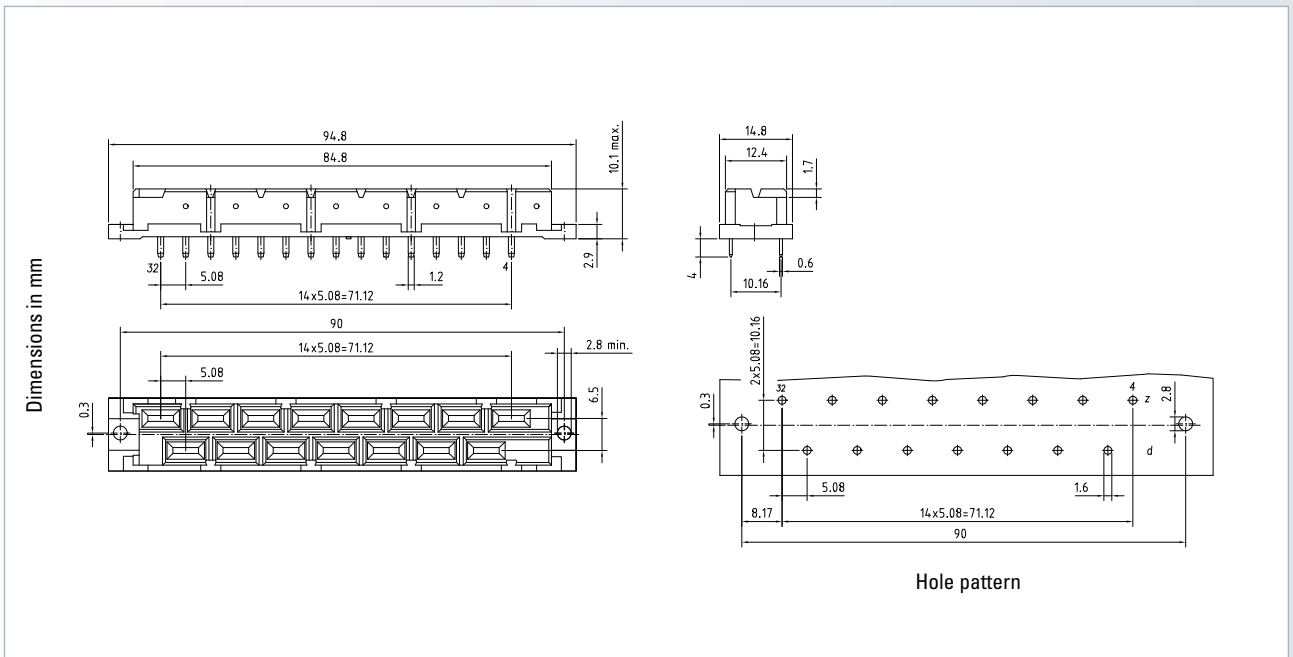

No. of contacts	Contact arrangement	Solder technology – Performance level II		
		Termination length		
				Manual soldering with solder lug
		Part number		
15		114-40080	114-40090	114-40100



Options – Board lock (see page 159)	Accessories – Coding accessories (see page 160)
---	---

Connectors according to DIN 41612 / IEC 60603-2

Type H7/F24

Male connector

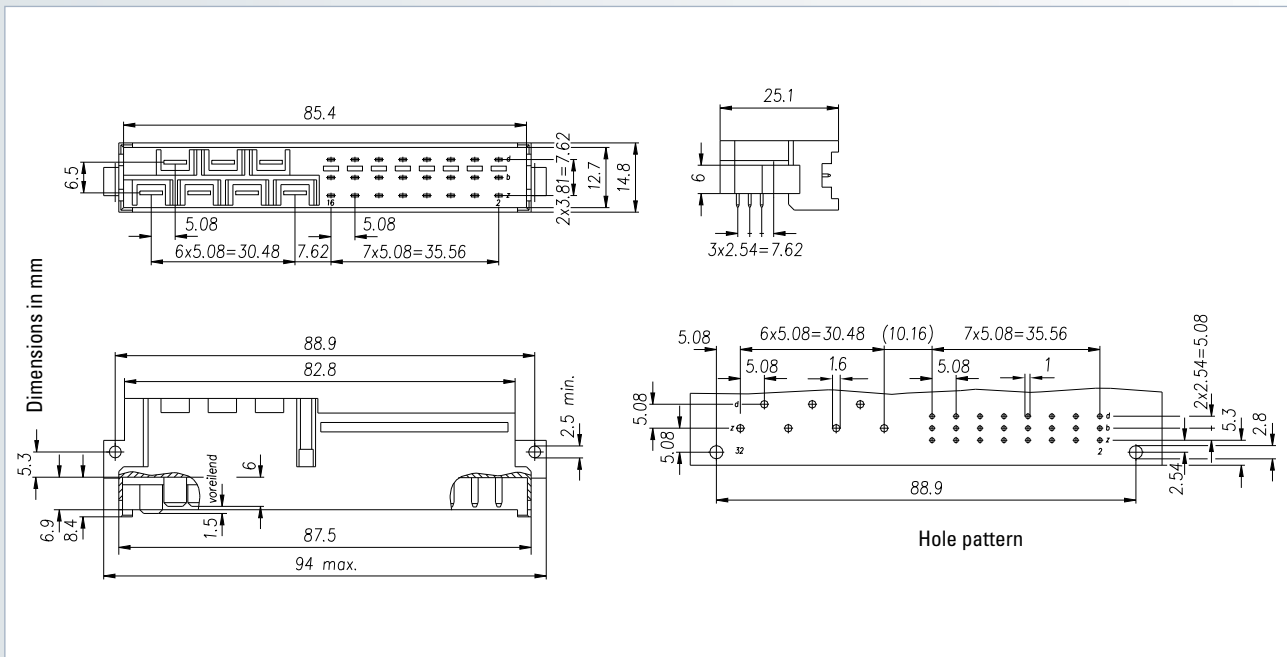

No. of contacts	Pre-mating contact at position	Contact arrangement	Solder technology – Performance level II	
			Termination length	Part number
7+24	Z 32			117-40164



Options

- Board lock (see page 159)

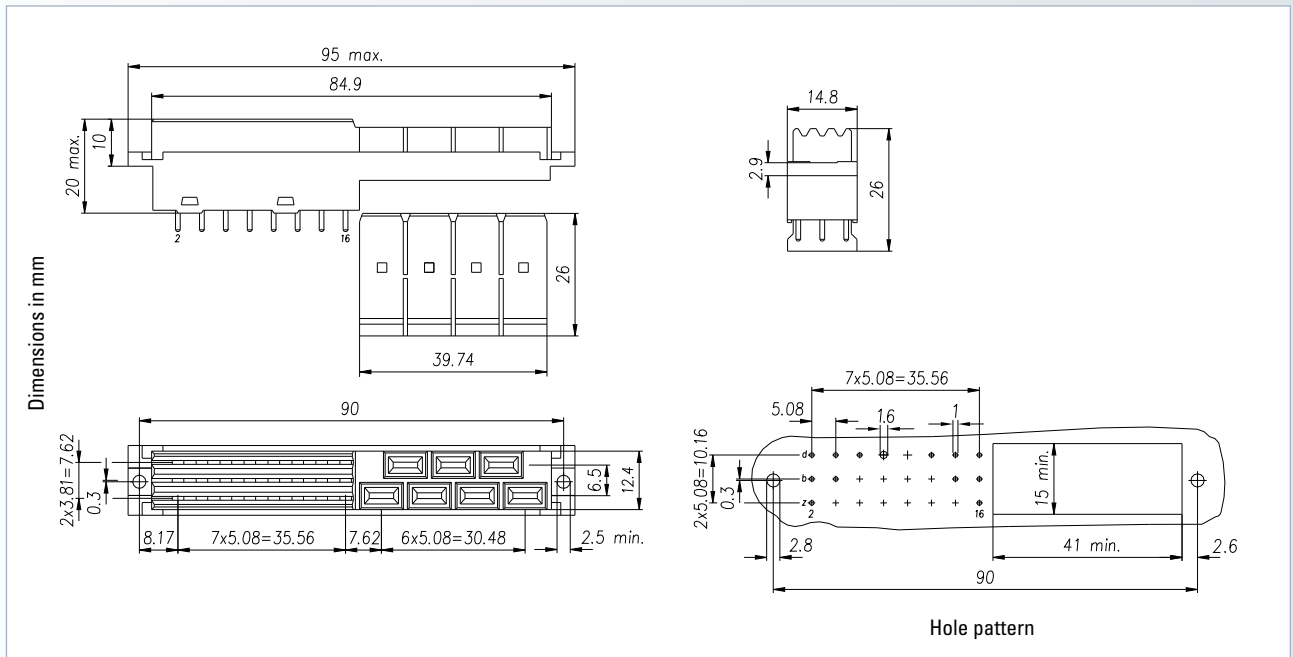

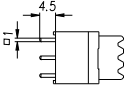
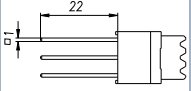
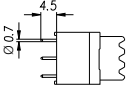
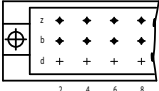
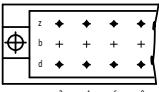
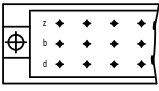
No. of contacts	Contact arrangement	Solder technology – Performance level II		
		Termination length		
				
Part number				
16		118-40025	118-40024	118-40005
16		118-40015	118-40014	118-40004
24		118-40065	118-40064	118-40084



On request

- Performance level I + III or customer-specific
- Special contact length
- Also in THTR
- Crimp contacts

Options

- Special contact arrangement (see page 162)

Connectors according to DIN 41612 / IEC 60603-2

Type H7/F24 low profile

Female connector

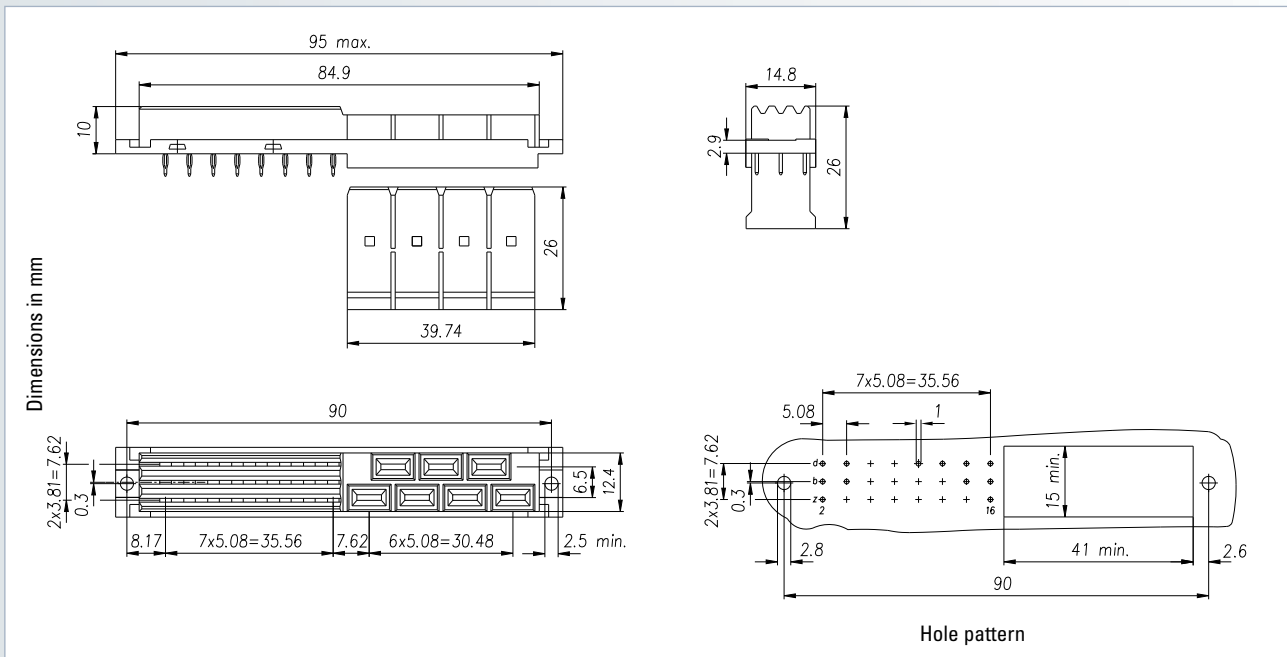

No. of contacts	Contact arrangement	Press-fit technology – Performance level II	
		Termination length	Part number
7+16			118-60016
7+16			118-60006
7+24			118-60084

On request

- Performance level I + III or customer-specific
- Special contact length
- Crimp contacts
- Press-fit tool
- Support tool

Options

- Without flange
- Special contact arrangement

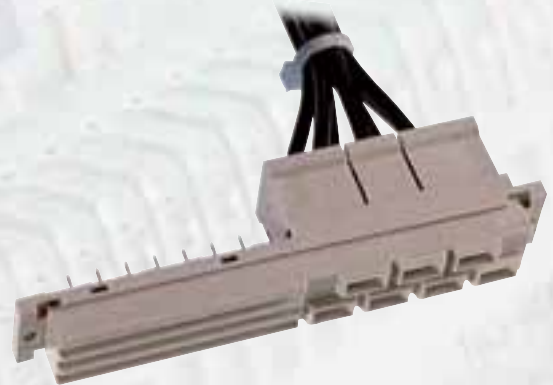

No. of contacts	Contact arrangement	Solder technology – Performance level II
		Termination length
		Part number
7+16		118-40505
7+16		118-40504
7+24		118-40584

On request

- Performance level I + III or customer-specific
- Special contact length
- Also in THTR
- Crimp contacts

Options

- Board lock (see page 159)
- Special contact arrangement (see page 162)

Connectors according to DIN 41612 / IEC 60603-2

Type VME 64x

Female connector

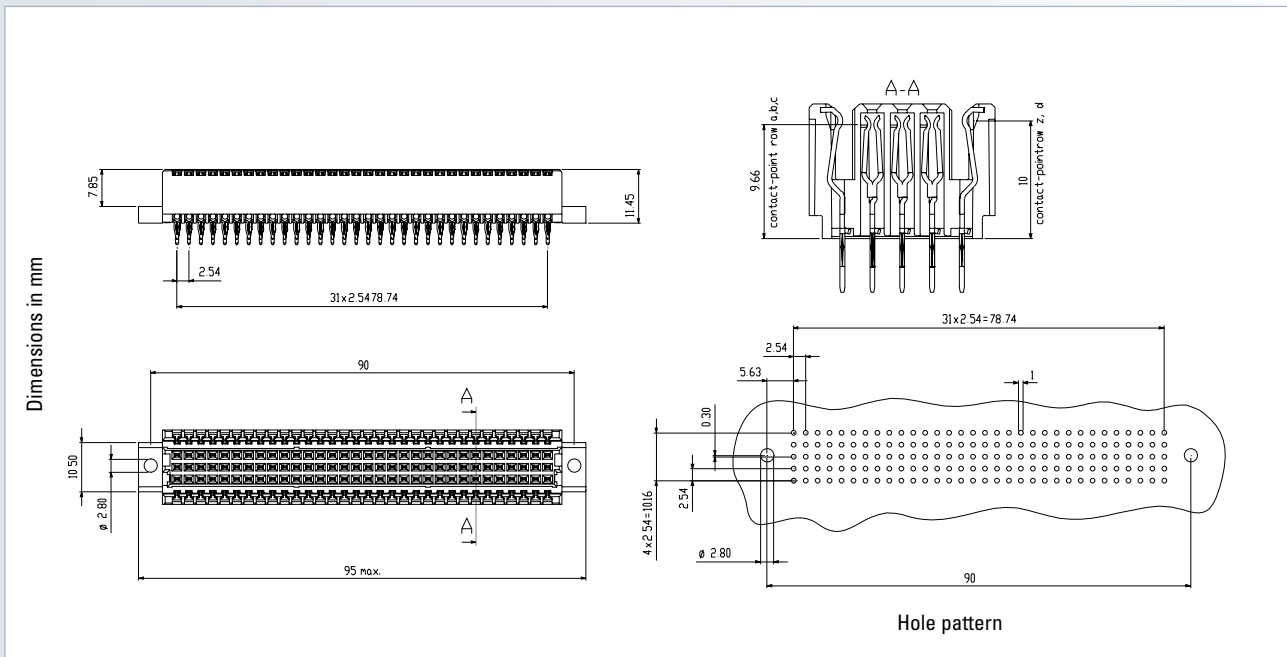

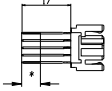
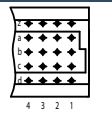
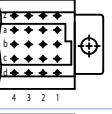
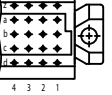
No. of contacts	Contact arrangement	Press-fit technology – Performance level I	
		Termination length	
			
		Part number	
160		306-61067-12	306-66069-14
160		306-60067-12	306-65069-14
160		306-62067-12	306-67069-14



Accessories <ul style="list-style-type: none"> – Press-fit tool (see page 208) – Support tool (see page 209) – Shroud (see page 153) 	On request <ul style="list-style-type: none"> – Performance level II + III or customer-specific – Special contact length 	Note <ul style="list-style-type: none"> – * Rear mating zone performance level I
--	---	--

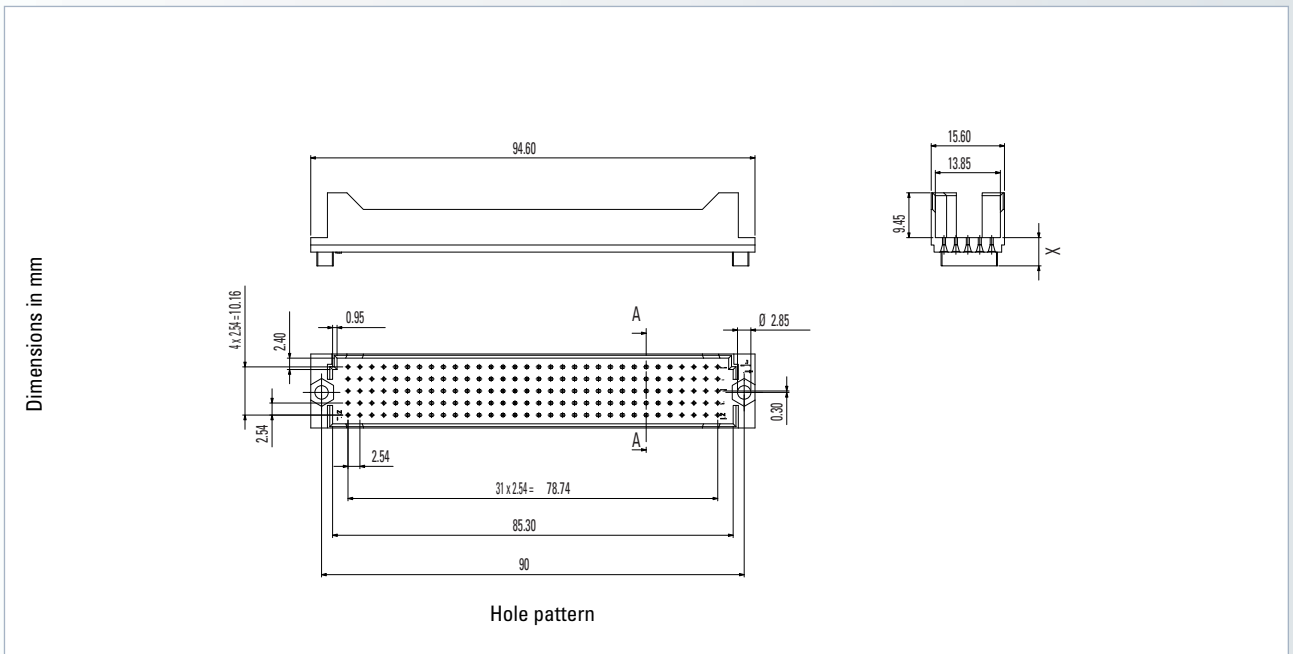

PCB thickness	X	Post length	Part number
			VME 64
3.4 mm	6.0 mm	17 mm	315-15401
4.6 mm	4.8 mm	17 mm	315-15402



On request

- Different designs and special types

Switching connectors – female connector with integrated switches

Problem

A principle often used for different bus systems is the looping-through of signal lines via module boards, the so-called “daisy chaining”:

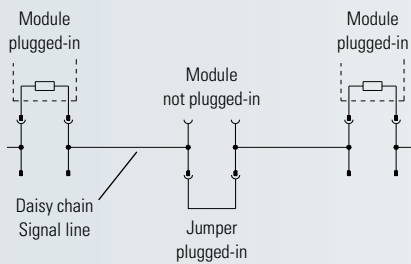

This daisy chaining, however, leads to a new problem, which becomes obvious when one of the modules is pulled from the system: The daisy chain signal connection is broken and must be re-established using jumpers. This is not easy as the modules are located close to each other in the rack. More often a large part of the housing must be taken apart or the whole endeavour of placing the jumper on the correct pins results in “nerve-wracking fumbling”. Mistakes and therefore mispositionings can happen.

A possible solution

The integration of switches into a standard connector according to IEC 60603-2, e.g. into a female connector type C, is a simple and elegant solution for the problem described. The contact springs of this C female connector were extended by wing-like contact tabs. A gold-plated metal disk is located between the contact springs. In rest position, with the male connector not plugged-in, the adjacent contact springs are short-circuited through placing of the contact tabs on the metal disk. With the male connector plugged-in, the contact springs are separated from each other through the contact pins of the male connector. The contact tabs of the spring are lifted off the metal disk. This interrupts the connection between the two springs. Due to the switching behavior of the C female connector, the daisy chain connection is automatically closed when the module board is pulled out. Function-wise the closed switching contact between two contact springs corresponds to a jumper automatically

being plugged in when the male connector is pulled out.

Application in the VME bus

The daisy chaining principle is used for the IACK and BG 0...3 signal lines in the VME bus.

By integrating a switching function at the positions of the respective signal lines in the connector, the jumpers used so far are no longer required.

Further applications

The integrated switching function is not restricted to the positions in the C female connector stated above. A switch can be integrated between any positions in the a, b and c rows of a C female connector IEC 60603-2 and/or between the a and c rows of a C female connector IEC 60603-2. A further application for ept switching connectors are e.g. network concentrators (hubs). In this application, too, the daisy chaining is carried out fully automatically via customer-specific switching connectors.

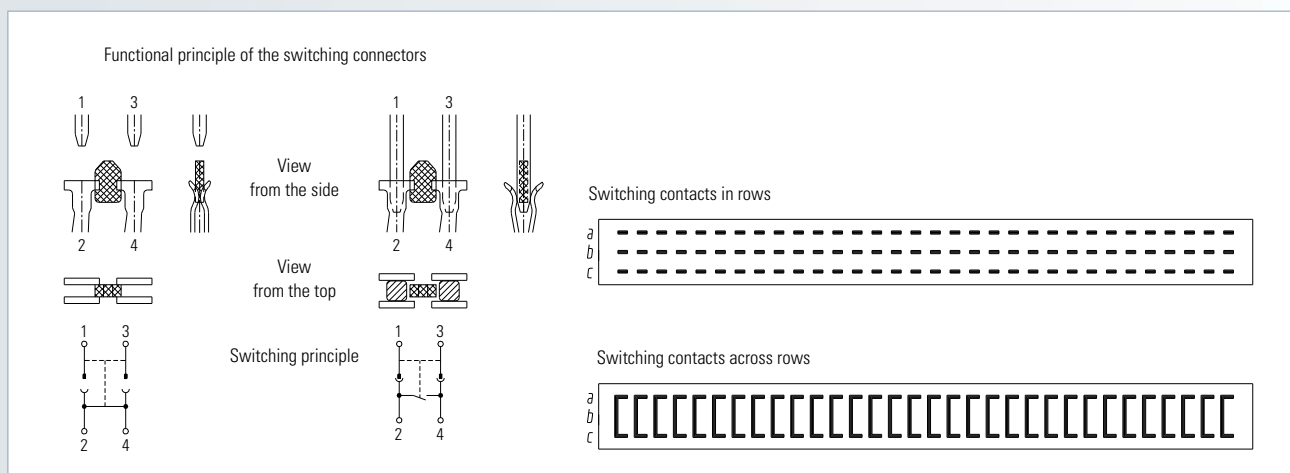

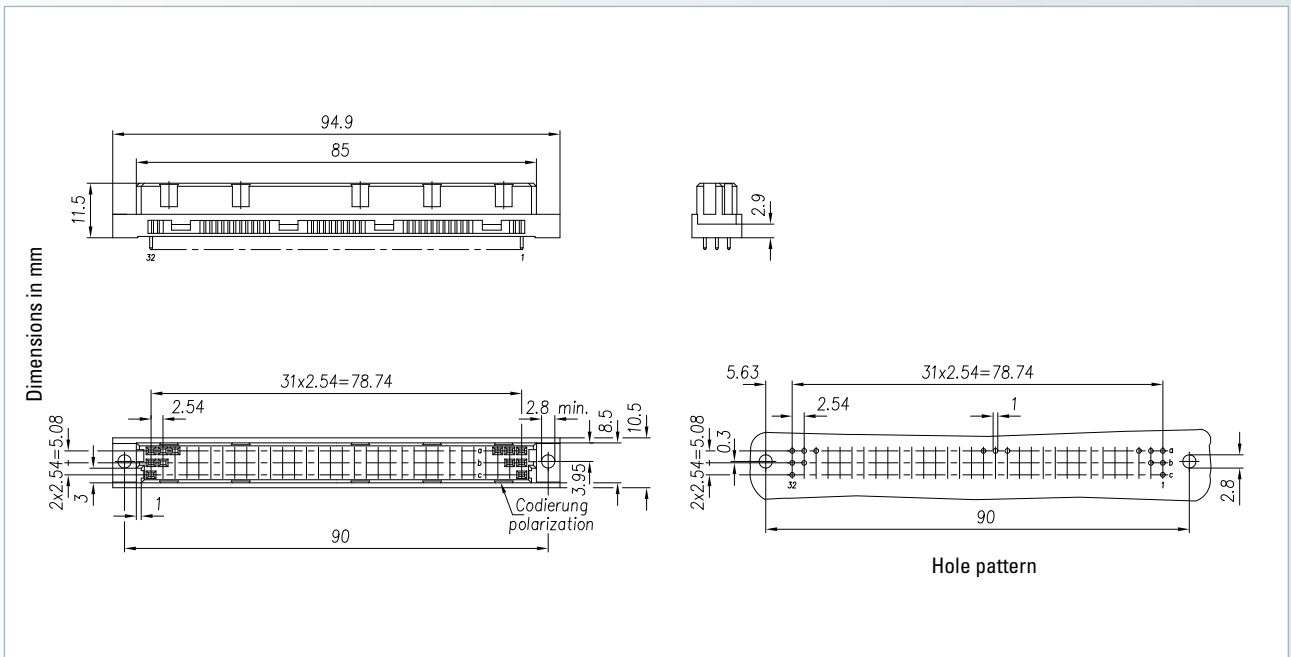

No. of contacts	Switching contacts at position	Press-fit technology – Performance level II		
		Termination length		
Part number				
96	a21 – a22, b4 – b5, b6 – b7, b8 – b9, b10 – b11 for VME	104-60464-xx	104-65465-xx	104-65466-xx
96	a – c 1, 2, 3, 4, ..., 32	104-60565-xx	104-65565-xx	104-65566-xx



<p>Accessories</p> <ul style="list-style-type: none"> – Press-fit tool (see page 208) – Support tool (see page 209) – Coding accessories (see page 160) 	<p>On request</p> <ul style="list-style-type: none"> – Performance level I + III or customer-specific – Special termination length 	<p>Options</p> <ul style="list-style-type: none"> – Without flange – Special contact arrangement (see page 162) – Customer-specific switching bridge positions (see page 163)
<p>Note</p> <ul style="list-style-type: none"> – * Rear mating zone performance level II 	<p>Ordering note</p> <ul style="list-style-type: none"> – PCB 1.5 to 2.0 mm = xxx-xxxx-01 with termination length = 3.2 mm – PCB 2.0 to 2.8 mm = xxx-xxxx-02 with on request – PCB > 2.8 mm = xxx-xxxx-03 with termination length = 4.6 mm 	

Connectors according to DIN 41612 / IEC 60603-2

IDC: type B and technical specifications

Female connector

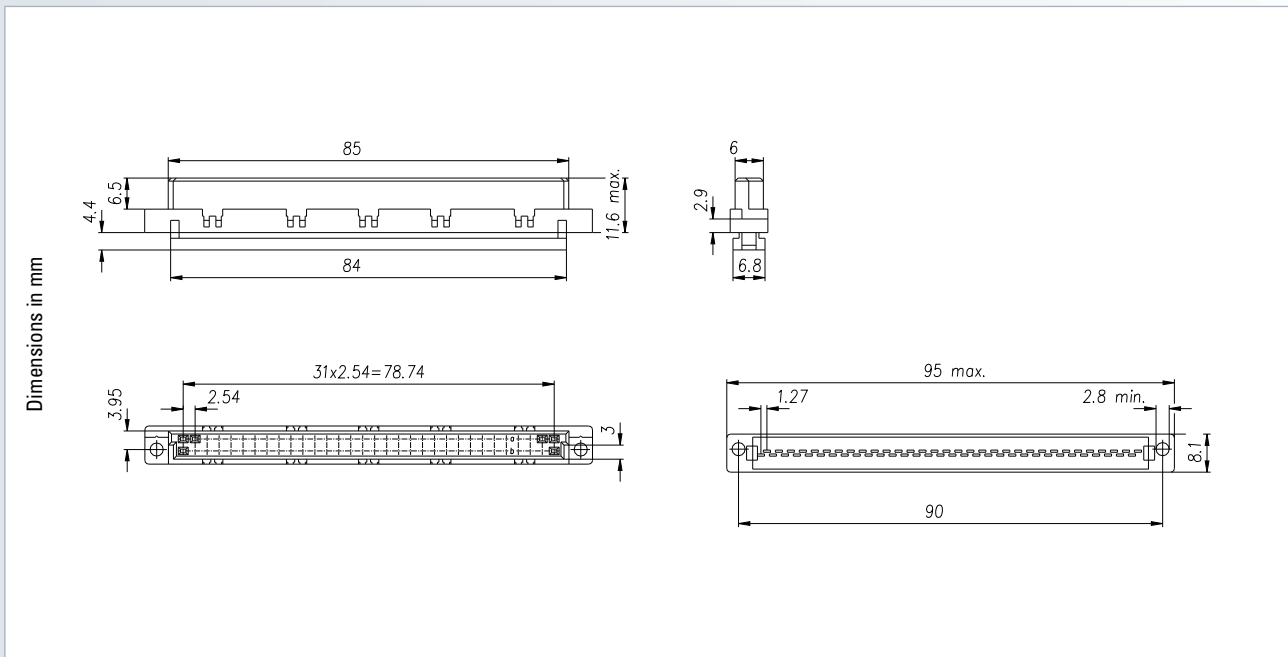

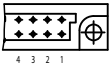
No. of contacts	Contact arrangement	IDC
		Performance level II
64		Part number
		102-49064

On request – Strain relief bracket – Ribbon cable	Options – Also available in solder/press-fit technology (see page 86)
--	---



Technical specifications IDC

Connections	IDC
Insulator material	Polyester, self-extinguishing UL 94 V0
Temperature range	-55 °C to +125 °C
Capacity	approx. 0.5 – 1 pF
Operational current	1 A at 20 °C

Operational voltage	220 V, 50 Hz
Test voltage	500 V/1.27 mm; 350 V/0.84 mm
Contact resistance	≤ 30 mΩ
Insulation resistance	≥ 10 ⁸ MΩ
Environment	RoHS compliant

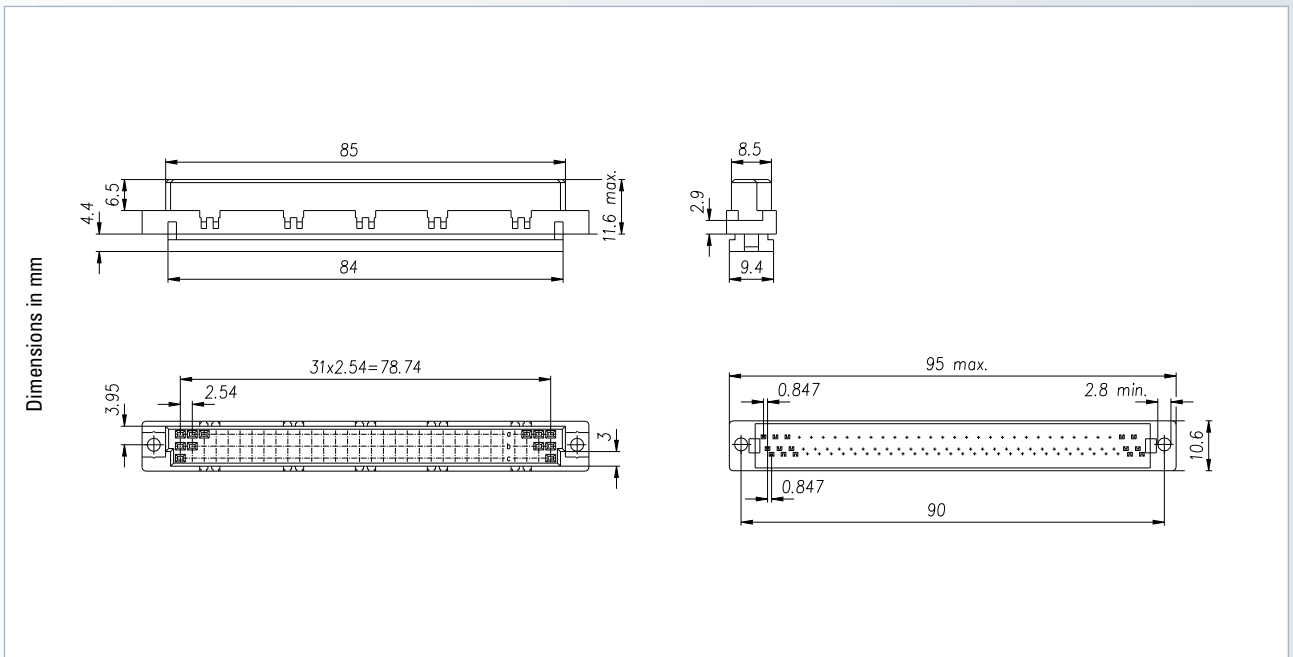

No. of contacts	Contact arrangement	IDC Performance level II
		Part number
64		104-49054
96		104-49064



<p>On request</p> <ul style="list-style-type: none"> – Strain relief bracket – Ribbon cable 	<p>Options</p> <ul style="list-style-type: none"> – Also available in solder/press-fit technology (see page 98)
--	---

Connectors according to DIN 41612 / IEC 60603-2

Accessories

Shroud

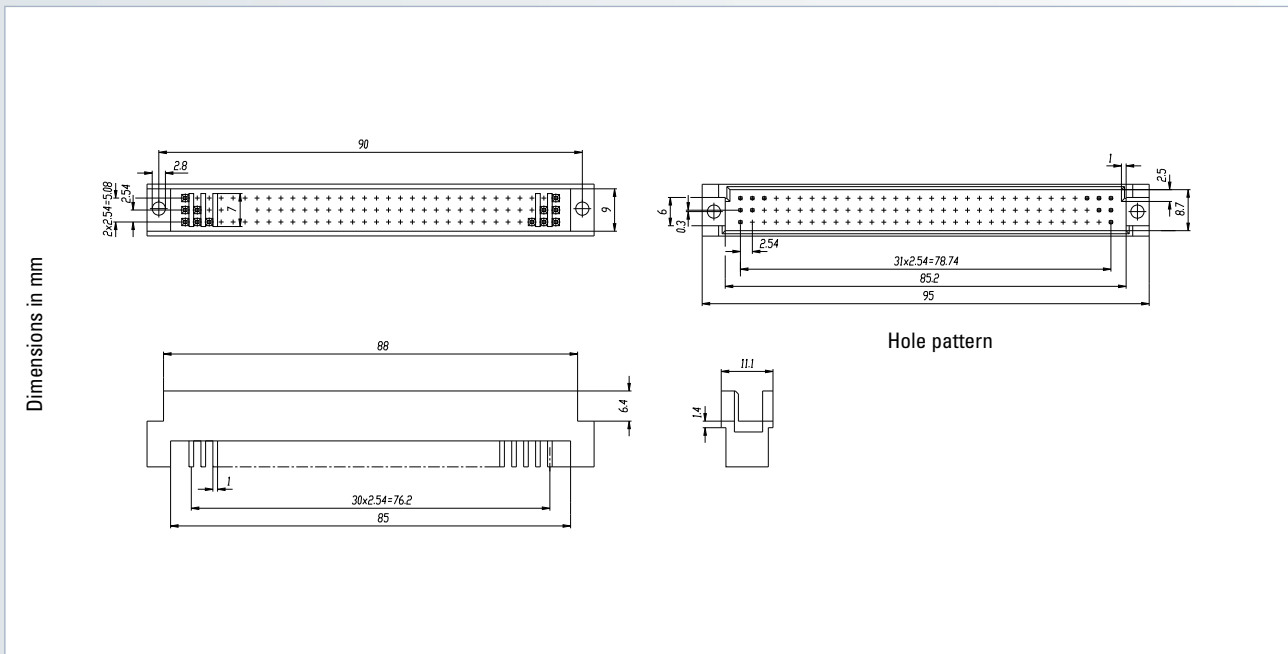

PCB thickness	Post length	Part number			
		C/R with nut	C/R	C/R self-retaining	C/R self-retaining without flange
2.4	13 mm	–	115-15401	–	–
2.4	17 mm	–	115-15301	–	–
3.2	13 mm	115-15701	115-15402	115-15405	115-15408
3.2	17 mm	115-15702	115-15302	–	–

On request



– Different designs and special types



Board lock

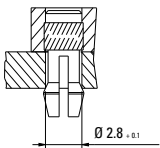

As an alternative to the rivet and/or screw fastening of the male and/or female connectors to the PCBs, connectors can also be mounted and held onto PCBs using board lock's. The connector with the board lock is pressed onto the PCB to be equipped. The board locks either lock into place or are under

tension. The connections are strong enough to hold the connector onto the PCB during the soldering process. Using plated mounting holes, soldering the board locks also essentially improves the strain relief of the connector during insertion and/or withdrawal.

Suitable for connectors with type B, C, D, E, F low profile, G low profile female connectors and R male connectors					
					
Type of insertion \ Forces	F_m	not soldered F_h	soldered F_h	Part number	PCB thickness
Locked	< 20 N	> 10 N	> 25 N	xxx-xxxxxC1	1.6 mm
Under tension	< 20 N	> 5 N	> 25 N	xxx-xxxxxC2	2.4 mm
				xxx-xxxxxC3	3.6 mm

F_m : max. mounting force per board lock
 F_h : min. retention force per board lock

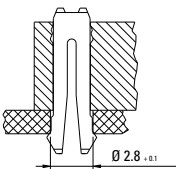
Ordering example: C-FL/PCB 1.6 mm, part number 104-40014C1

Suitable for connectors with type B, C, D, E, F, G male connectors and R female connectors					
					
Type of insertion \ Forces	F_m	not soldered F_h	soldered F_h	Part number	PCB thickness
Locked	< 30 N	> 10 N	> 20 N	xxx-xxxxxC1	1.6 mm
Under tension	< 30 N	> 7.5 N	> 20 N	xxx-xxxxxC2	2.4 mm
				xxx-xxxxxC3	3.6 mm

F_m : max. mounting force per board lock
 F_h : min. retention force per board lock

Ordering example: C-ML/PCB 1.6 mm, part number 103-40014C1

Additional information

Coding

Coding without losing contacts

Type B and C

The integrated coding of the connectors with type B and C prevent that the wrong modules are plugged in. For

coding, coding wedges are inserted into the female connector and matching parts are broken out of the insulator

material of the male connector with coding pliers.

Coding	Coding star (4 coding wedges)	Coding pliers						
<p>1) Break-out coding</p> <p>2) Insert coding wedge into the female connector</p>								
	<table border="1"> <thead> <tr> <th>Part number</th> <th>Packaging unit</th> </tr> </thead> <tbody> <tr> <td>104-19003</td> <td>25 stars</td> </tr> </tbody> </table>	Part number	Packaging unit	104-19003	25 stars	<table border="1"> <thead> <tr> <th>Part number</th> </tr> </thead> <tbody> <tr> <td>894-301</td> </tr> </tbody> </table>	Part number	894-301
Part number	Packaging unit							
104-19003	25 stars							
Part number								
894-301								

Type D, E, F and G

With connectors with type D, E, F and G holes can be drilled into the male connector and pins can be inserted

into the female connector in matching positions.

Male connectors	Female connectors								
Drill coding hole with gauge.	Insert coding pin into the coding hole using the insertion tool.								
	<table border="1"> <thead> <tr> <th>Part number – coding pin</th> <th>Packaging unit</th> </tr> </thead> <tbody> <tr> <td>106-10001</td> <td>100 items</td> </tr> <tr> <th>Part number – insertion tool</th> <td></td> </tr> <tr> <td>894-302</td> <td></td> </tr> </tbody> </table>	Part number – coding pin	Packaging unit	106-10001	100 items	Part number – insertion tool		894-302	
Part number – coding pin	Packaging unit								
106-10001	100 items								
Part number – insertion tool									
894-302									

Type H11 and H15

Keying plug

Coding	Part number
	114-30000

Pre-mating and late-mating contacts

For DIN type B, C, R, D, E, F, G

The pre-mating contact can – as special contact arrangement – be inserted into any desired position.

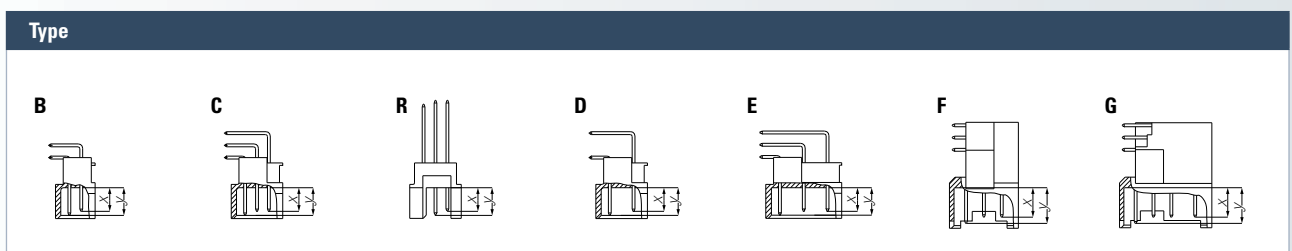

Type	Standard (X)	Pre-mating (Y)			Late-mating (Y)	
		+ 0.8 mm	+ 1.0 mm	+ 1.3 mm	- 0.4 mm	- 0.8 mm
B, B/2, B/3, C, C/2, C/3	4.9	–	5.9	–	–	4.1
R, R/2, R/3	Mating side	4.9	5.7	5.9	–	4.5
	Termination side	13.0	13.8	–	–	12.6
D	4.9	5.7	–	–	–	–
E (grid 2.54 mm)	4.9	5.7 Rows a, c, e	–	–	–	–
E (grid 5.08 mm)	4.9	5.7 Row a	–	–	–	–
F, G	6.1	–	–	7.4	–	–

On request

– Other lengths possible for pre-mating and late-mating

